



**ELECTRIC DRIVES**  
FOR EVERY DEMAND



**Catalogue 2018**

**Low Voltage  
Drive Systems**

VEMoDRIVE



## **ELECTRIC DRIVES**

FOR EVERY DEMAND



**Transportation**



**Machine and plant engineering**



**Steel and rolling mills**



**Cement and mining industry**



**Shipbuilding**



**Chemical, oil and gas industry**



**Water management**



**Renewable energy**



**Power plant technology**

There are currently around 30 million electric machines bearing the VEM badge in use around the world. They are found aboard ships, in trains and trams, and in chemical plants and rolling mills. VEM generators produce electricity in hydropower plants and wind farms.

The VEM product range embraces variable-speed electric drive systems, special motors and special machines for outputs ranging from 0.06 kW to 42 MW, as well as a diversity of drive technology and power generation components.

## Low Voltage Drive Systems

### Contents

Seite

<b>Introduction</b>	<b>4</b>
<b>Principal components of a drive system</b>	<b>4</b>
<b>Output and torque</b>	<b>4</b>
<b>Additional stresses placed on motors in inverter-fed operation</b>	<b>5</b>
Thermal stresses	5
Estimation of temperature rise	5
Motor voltage and winding specification	5
Speed-torque characteristics	6
Range of constant flux (constant pull-out torque)	6
Field weakening range	7
Special variant of 87 Hz operation	8
Voltage stresses (insulation systems)	9
NAMUR	10
Bearing stresses (insulated bearings)	10
Information required for drive specification	10
<b>Basic data of inverters</b>	<b>10</b>
Mains voltage ranges	10
Overload capacity and degree of protection	10
Cooling	11
Switching frequency	11
<b>Options</b>	<b>11</b>
Motors	11
Inverters	12
<b>Technical data/selection tables</b>	<b>13</b>

## Introduction

This catalogue supplies information which must be observed when selecting motors and inverters. With the aid of this information, it is possible to modify not only the mechanical, but also the electrical components of motors for inverter-fed operation. The interactions of the components

inverter, motor cable and motor, and likewise the influences of particular options, must be known. Inappropriate selections when planning a drive system usually only become evident after they result in winding and/or bearing damage.

## Principal components of a drive system

A variable-speed drive system comprises the following components (see Fig. 1):

- **Incoming power supply** (line fuses, main switch, supply contactor, etc.)
- **Input components** (interference suppression filters, line reactors, etc.)
- **Inverter** (including options, e.g. brake module)
- **Output components** (reactors, du/dt or sine-wave filters, etc.)

- **Motor cable** (important: length, type, routing, shielding, etc.)
- **Motor** (standard or special insulation, insulated bearings, etc.)

Careful specification of the individual components guarantees a long service life for the drive system and reliable compliance with the applicable regulations on EMC and mains pollution, as well as energy efficiency and an optimum price-performance ratio.

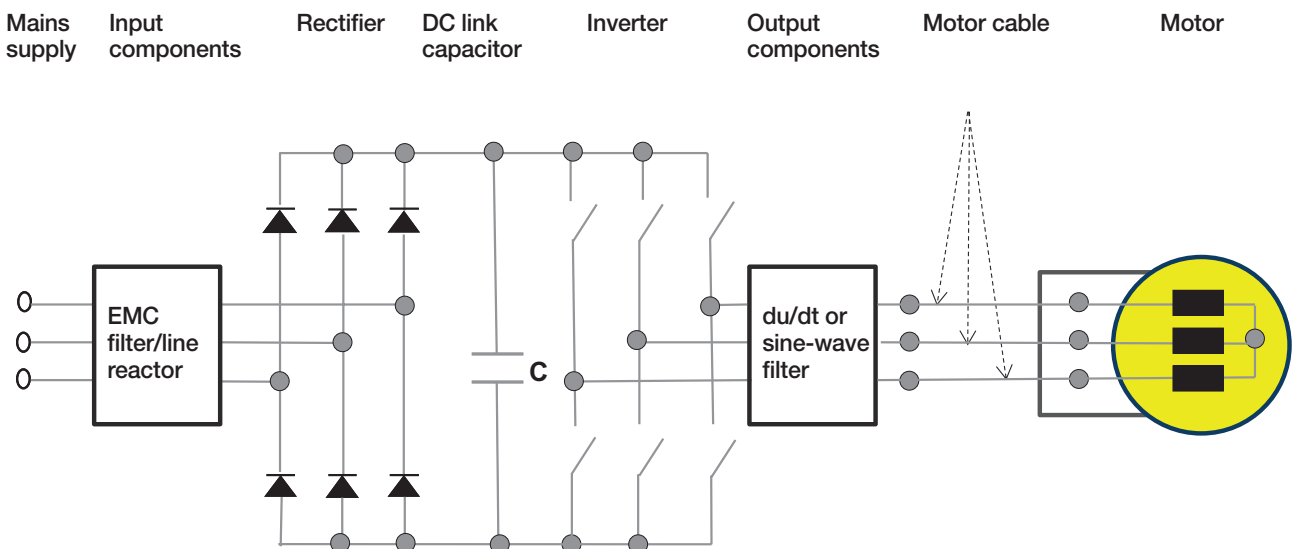

Fig. 1: Principal components of a drive system

## Output and torque

In inverter-fed operation, the operating speed of the working machine can deviate from the 50 or 60 Hz rated speed of the motor. In such cases, the optimum number of poles must be determined and the power rating must be calculated or checked.

Information on the working machine and the technological process is imperative for optimum drive specification. It must be known whether a fluid machine or some other kind of machinery, e.g. conveyors, cranes, etc., is to be driven.

- With fluid machines, no further information is required if the maximum frequency corresponds to the rated frequency of the motor. Motors can be selected for the 100 % operating point, together with inverters for low overloads.
- For all other working machines, a speed-torque characteristic or at least information on certain operating points within the speed setting range is useful (for examples, see Fig. 2). If high torques are required over a longer period at low motor speeds, the duration of the load or duty cycle must be specified.

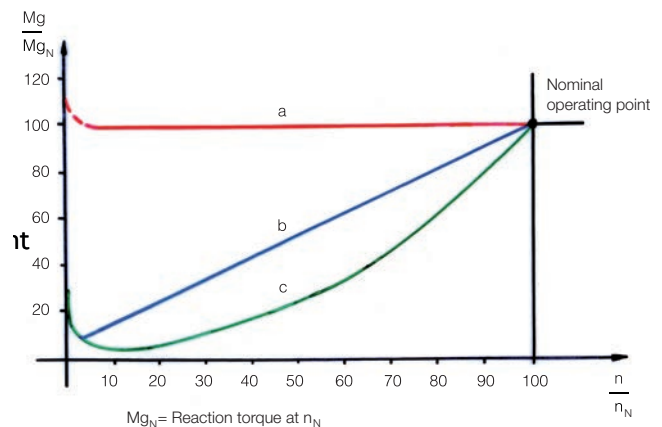

Fig. 2: Typical torque characteristics of working machines

- a. **Constant** torque over a speed range (winches, conveyors, etc.)
- b. **Linearly increased** torque with increasing speed
- c. **Quadratically increased** load torque characteristic (typical for fluid machines such as pumps and fans)

**Example:** 100 % operating point of a fan:  
100 kW at 2400 rpm  
What is the optimum number of poles for the motor?

#### 4-pole motor:

The 100 % operating point of the fan – at 2400 rpm – lies above the rated speed of the 4-pole motor. At 2400 rpm (80 Hz), the 100 % rated output of the motor is still available (see section: Field weakening range)

At 80 Hz, however, the motor possesses only limited overload capacity. Undervoltage at the motor terminals results in quadratic further reduction of the overload capacity. This must be placed in relation to the quadratically increasing torque of the fan with increasing speed. Speed changes thus result in cubic output changes. As an increased power demand can never be fully excluded in practical operation, a reserve of 10 – 15 % should be planned for variable-speed motors which drive fluid machines. A further reserve of approx. 5 % is recommended to allow for the lower terminal voltage compared to the rated voltage of the motor, which means that a motor with an output of at least 120 kW should be selected. The appropriate choice is thus a 4-pole motor with a power rating of 132 kW.

If the motor operates above the rated frequency, it is possible to extend the range of constant torque by selecting a special winding. The output can thus be increased from 110 kW at 50 Hz to 132 kW at 60 Hz.

It is possible to use both a 4-pole 132 kW motor with 50 Hz standard winding and a 4-pole 132 kW motor with 60 Hz special winding. The latter possesses a lower mass and displays a higher overload capacity due to its lower field weakening.

#### 2-pole motor:

To be able to calculate the output for a 2-pole motor, it is first necessary to determine the required torque  $M$  of the working machine.

$$M [Nm] = \frac{P [kW] \cdot 9550}{n [rpm]} \quad 398 Nm = \frac{100 kW \cdot 9550}{2400 rpm}$$

Taking the torque  $M$  and the estimated rated speed  $n$ , the power output  $P$  of the 2-pole motor can be calculated with:

$$P [kW] = \frac{M [Nm] \cdot n [rpm]}{9550} \quad 124 kW = \frac{398 Nm \cdot 2975 rpm}{9550}$$

This produces a power rating of 132 kW for the 2-pole motor.

#### Recommendation for the 2-pole motor:

A 2-pole motor is the ideal choice for standard motors. In this case, it is only operated at up to 40 Hz, which has a positive effect on the overall efficiency of the drive system, the noise level and the overload capacity.

#### Recommendation for the 4-pole motor:

A 4-pole motor with a 60 Hz **special winding** and 60 Hz output is a good alternative to a 2-pole motor. The potential benefit of a slightly lower mass must be weighed up against the increased fan noise and the slightly higher power losses of the drive system.

The use of a 4-pole 132 kW standard motor is a less recommended alternative due to the limited overload capacity, and is at the same time more expensive.

## Additional stresses placed on motors in inverter-fed operation

### Thermal stresses

The additional thermal losses in inverter-fed operation result in increases of up to 15 K in the winding temperatures on the stator and rotor. In the case of 2- and 4-pole motors **without efficiency classification** (e.g. K21R series), the increased winding temperature rise may make it necessary to reduce the rated torque and thus the rated output.

With IE2 and IE3 motors, the possibly necessary output reduction must be taken into account from size 315.

#### Estimation of temperature rise

VEM motors are manufactured for assignment to thermal class 155 (F) as standard.

Use of IE2 and IE3 motors up to shaft height 280 in mains-fed operation



Thermal class 130 (B)



The rated output of the IE2 and IE3 motors up to shaft height 280 is also available in inverter-fed operation. With 2- and 4-pole IE2 motors, inverter-fed operation may lead to exceeding of thermal class 130 (B), such that use in accordance with thermal class 155 (F) is assumed (F/F).

**F/B** means that the motor was manufactured in accordance with thermal class 155 (F), but the temperature

rise remains within the limits specified for thermal class B (maximum temperature rise 80 K).

**F/F** means that the motor was manufactured in accordance with thermal class 155 (F) and that the temperature rise in use also corresponds to thermal class F (maximum temperature rise 105 K).

**To avoid unnecessary overdimensioning, it is expedient to refer the specification F/B to the required torque and output of the working machine rather than the rated output of the motor.**

#### Motor voltage and winding specification

With motors intended for inverter-fed operation, a **star connection** is the preferred operating connection.

The inverters can be connected to mains power supplies with a wide voltage range (see section “Mains voltage ranges”) and generally produce an output voltage which is lower than the mains voltage (with an uncontrolled input current inverter). Components such as line reactors, output filters, cables etc. lead to further voltage losses. For this reason, inverter-fed motors should be planned with a special winding for a voltage less than the nominal mains voltage as a means to compensate mains undervoltages. That is especially recommended where working machines utilise

the full rated output of the motors. Mains overvoltages are compensated by the inverter itself and pose no threat to the motor and its insulation system.

When the drive is commissioned, the inverter must be parameterised with the motor data. Tolerance specifications for the voltage and frequency, input voltage range, Zone A, Zone B, etc. are not taken into account. After parameterisation with the rating data, the motor will be fed optimally.

### Example:

Mains voltage: 415 V +10 %/-15 %  
 Lowest mains undervoltage: 415 V -15%: ≈ 353 V  
 Estimated lowest voltage at the motor terminals: approx. 342 V  
 Motor winding specification: 342 V/0.95: 360 V Y **(star)**  
 It is recommended to divide the estimated lowest voltage at the motor terminals by 0.95 in order to determine the motor voltage when the standard tolerance of ± 5 % is applied. The standard tolerance is not specified explicitly and thus not marked on the rating plate.

In this case, a 360 V Y special winding is only meaningful if the power demand of the working machine is greater than 85 % of the rated motor output. If the voltage at the motor terminals lies within the normal range of ± 5 %, the thermal

reserves of the motor will generally be sufficient for continuous operation at rated output.

If, on the other hand, a motor with a 415 V Y, 50 Hz winding is used, the inverter must be parameterised with the 415 V rating data. If the mains voltage drops to 360 V during operation, the start of the field weakening range is shifted from 50 Hz to 43 Hz. The motor current increases with a constant increase in torque, which may lead to thermal overloading of the motor and possibly also the inverter. The upper frequency limit of the range of constant output is shifted to a lower frequency (see also Fig. 4).

### Sine-wave filter

Due to the voltage drop of approx. 25 V, the winding voltage for a motor fed via a sine-wave filter must similarly be reduced compared to the mains voltage.

### Note:

In some cases, it may well be expedient to forego voltage adaptation (i.e. specification of a special winding) for inverter-fed motors. This is possible with motor sizes ≤ 280, if a IE2 or IE3 motor is used and if, in case of doubt, the motor with the next higher power rating is chosen. For non-stock motors, the special winding will represent the more cost-effective solution.

## Speed-torque characteristics

### Range of constant flux (constant pull-out torque)

It is possible to set a constant flux for inverter-fed motors over the frequency range up to 50 Hz or 60 Hz. Where the motor flux is constant, the maximum (pull-out) torque is likewise constant. On the basis that the ratio U/f remains constant, the voltage rise V/Hz (1 Hz = 1 s<sup>-1</sup>) and thus the voltage at any given frequency within the range of constant flux can be determined.

### Example:

Motor winding (global standard voltage): 400 V/50 Hz  
 Nominal mains voltage (acc. to NEMA): 480 V/60 Hz  
 Effective voltage (acc. to NEMA): 460 V +/-10 %/60 Hz

$$400 \text{ V}/50 \text{ s}^{-1} = 8 \text{ V/s}$$

$$460 \text{ V}/8 \text{ V/s} = 57.5 \text{ s}^{-1} = 57.5 \text{ Hz}$$

The 400 V, 50 Hz motor can be operated both at 400 V/50 Hz with rated output and at 460 V with 57.5 Hz and 115 % rated output when fed via a inverter connected to a 480 V mains supply. The field weakening range begins either at 50 Hz or else only at 57.5 Hz, depending on the parameterisation. Thanks to their thermal reserves, most motors are able to deliver the 60 Hz output, i.e. 120 % rated output, at 60 Hz (460 V).

The 400 V motor can also be operated at 95 % rated output on a 380 V mains supply. As 47.5 Hz lies within the range of constant flux for a 50 Hz motor, the inverter parameterisation deviates from the rating plate data (380 V; 47.5 Hz; 0.95 x rated output, rated current and cosφ as per rating plate).

The new speed is the synchronous speed minus the rated slip speed.

Synchronous speed:

$$n_s = \frac{f \cdot 120}{p} \quad [p - \text{pole number (2, 4, 6, 8 \dots)}]$$

$$\text{Rated slip speed: } n_{\text{slip}} = n_s - n_N$$

$$\text{Speed at new frequency: } n_{\text{new}} = n_s - n_{\text{slip}}$$

This approximate calculation of the new speed parameter can be used for frequencies to around 40 Hz.

### Important:

**If the nominal mains voltage lies above the rated motor voltage, the insulation system must be selected according to the higher mains voltage and not the rated voltage of the motor (taking into account the chosen output connection design).**

### High continuous torque in the low frequency range

The speed setting range in inverter-fed operation permits self-ventilated motors to be operated at frequencies down to 20 Hz without reducing the rated torque. Typical torque characteristics are shown in Fig. 3.

Increased torque can also be realised without forced ventilation at lower frequencies in either of the following ways:

- Use of a self-ventilated motor with the next higher power rating
- Use of a motor whose thermal capacities are utilised to a lesser extent, e.g. an IE3 motor

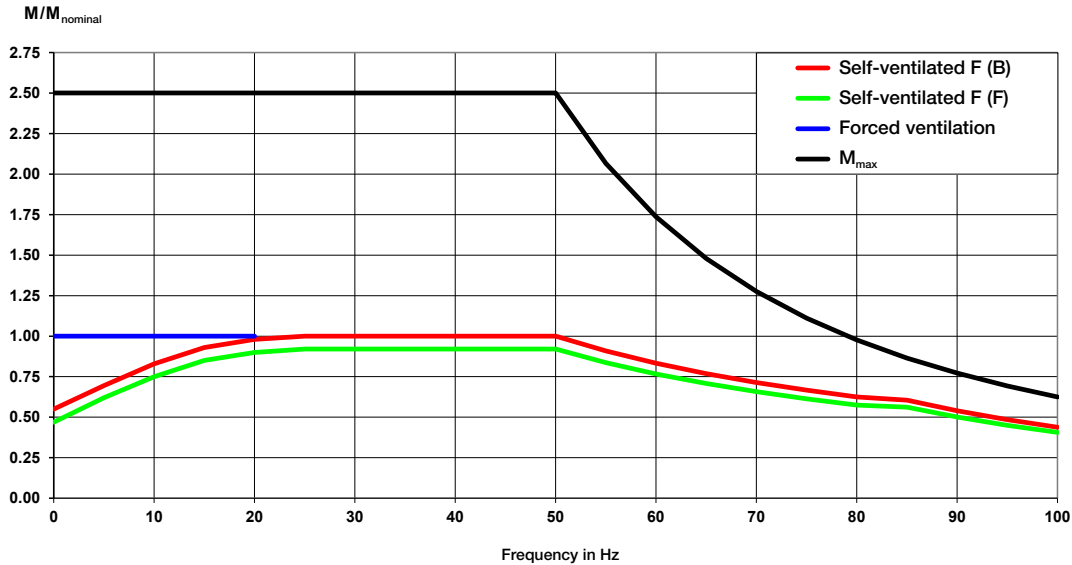

Fig. 3: General thermal limit characteristics of squirrel-cage motors with self- and forced ventilation in operation according to thermal classes B and F, plotted alongside the  $M_{max}$  (pull-out torque) characteristic

**General note:**

There are no thermal reasons for forced ventilation when driving fluid machines such as pumps and fans. Forced ventilation may nevertheless be appropriate to reduce the noise level at motor speeds above the rated speed.

**Field weakening range**

Motors which are operated above the rated frequency with constant voltage ( $U = \text{constant}$ ) are working in the field weakening range.

**In the field weakening range, the maximum motor torque drops quadratically with increasing frequency.**

The field weakening range can be divided into two sections, with the transition frequency between the two being dependent on the pull-out torque of the motor at the rated operating point.

1. Range of constant output ( $P = \text{constant}$ )  $\rightarrow$  from  $f > 50$  Hz; from  $f > 60$  Hz, the available continuous torque drops linearly with increasing frequency
2. Range of linearly decreasing output  $\rightarrow$  Due to the quadratically decreasing pull-out torque in the field weakening range, the available torque also decreases quadratically from a frequency dependent on the pull-out torque of the motor at the rated operating point, with the result that the output drops linearly with increasing frequency.

The maximum torque (pull-out torque) in the field weakening range can be calculated as follows:

$$M_{max} = \left(\frac{f_{transition}}{f_{operating}}\right)^2 \times M_{pull-out}$$

$f_{transition}$  – Frequency at which the field weakening range begins

$f_{operating}$  – Frequency in the field weakening range (above the transition frequency)

$M_{pull-out}$  – Pull-out torque of the motor at rated voltage and frequency

**Note:**

- a. To guarantee reliable operation of the motor, a reserve of at least 30% must be observed between the maximum motor torque (pull-out torque) and the required torque of the working machine.

$$M_{working\ machine} \leq M_{max} \times 0.7$$

For a 50 Hz motor with a relative pull-out torque of 2.5, the range of constant output ends at approx. 85 Hz (see Fig. 3).

The maximum motor torque and the required torque of the working machine can be calculated as follows:

Maximum motor torque (pull-out torque) in the field weakening range:

$$M_{max} = \left(\frac{f_{transition}}{f_{operating}}\right)^2 \times M_{pull-out}$$

Required torque:  $M_{working\ machine} [Nm] = \frac{P [kW] \cdot 9550}{n [rpm]}$

- b. In various circumstances, the field weakening range may already begin below the rated frequency of the motor. This is always true, for example, where a voltage of only 360 V is present at the terminals of a 400 V/50 Hz motor connected behind an output filter or with long cables. In this case, field weakening already begins from 45 Hz (see Fig. 4). The range of constant output ends at approx. 80 Hz.

- For drive applications where premature field weakening and the consequently higher thermal stress must be avoided, the following solutions are possible:
- $\rightarrow$  For stock motors with standard winding 230/400 V D/Y, 50 Hz
  - Select a motor with a higher power rating
  - $\rightarrow$  For non-stock motors
  - Use a motor with special winding, e.g. 360 V Y, 50 Hz

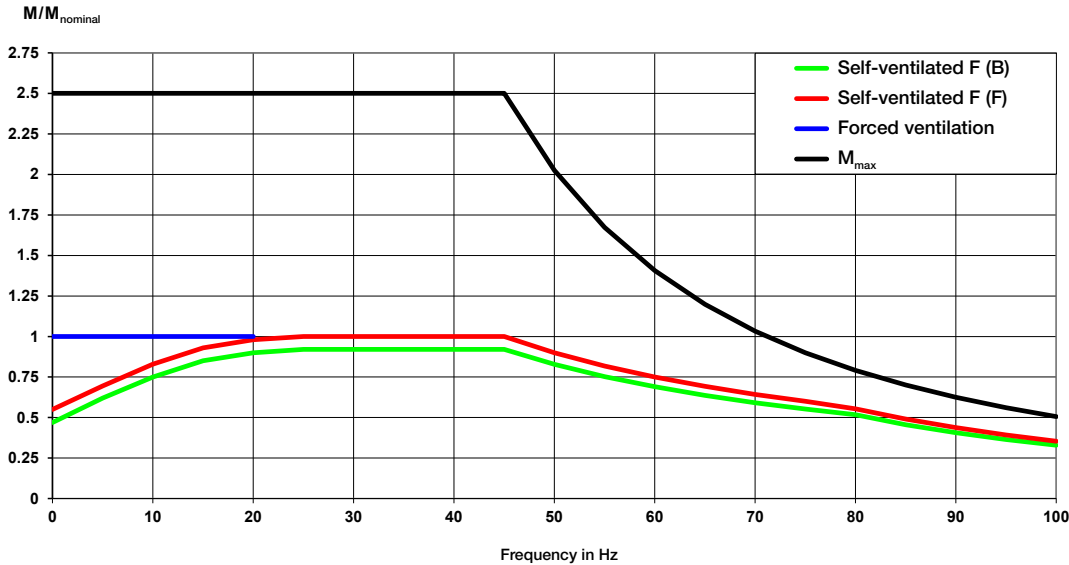

Fig. 4: General thermal limit characteristics of squirrel-cage motors with self- and forced ventilation in operation according to thermal classes B and F, plotted alongside the pull-out torque characteristic taking into account a 10% voltage reduction at the motor terminals

**Special variant of 87 Hz operation**

The special variant of 87 Hz operation describes a possibility to raise the output of a inverter-fed motor. Where the rating plate of a squirrel-cage motor specifies two voltages which differ from each other by the factor  $\sqrt{3}$ , the lower voltage applies for delta connection of the motor, the higher voltage for star connection. If the maximum output voltage of the inverter corresponds to the higher rating plate voltage (star connection), the motor can also be operated in delta connection ( $\Delta$ ) if the output frequency is similarly raised by the factor  $\sqrt{3}$  from 50 Hz to 87 Hz.

**Example:** Mains voltage: 400 V, 50 Hz  
 Marking of motor: 230/400 V  $\Delta/Y$ , 50 Hz

**Motor connection variants**

- Three-phase mains supply 400 V, 50 Hz: Y
- Inverter on 400 V mains: Y  $\rightarrow$  Parameterisation: 400 V, 50 Hz
- Three-phase mains supply 230 V, 50 Hz:  $\Delta$
- Inverter on 400 V mains:  $\Delta \rightarrow$  Parameterisation: 400 V, 87 Hz

It was already mentioned in the section “Motor voltage and winding specification” that star connection is the preferred configuration for the operation of inverter-fed motors. The special variant of 87 Hz operation consciously foregoes the benefits of this connection for inverter-fed operation.

It can be seen from Fig. 5 that the rated torque ( $M/M_{nominal} = 1.00$ ) of a motor in the output class  $> 7.5$  kW will not usually be available in continuous operation at 87 Hz. Depending on the motor size and specification, it must be reduced by up to 18% in continuous operation.

**Benefits of 87 Hz operation:**

- Increased speed raises the continuous output of motors  $\leq 7.5$  kW by the factor  $\sqrt{3}$
- Speed setting range extended by the factor  $\sqrt{3}$  with constant torque
- Reduced mass moment of inertia of the rotor

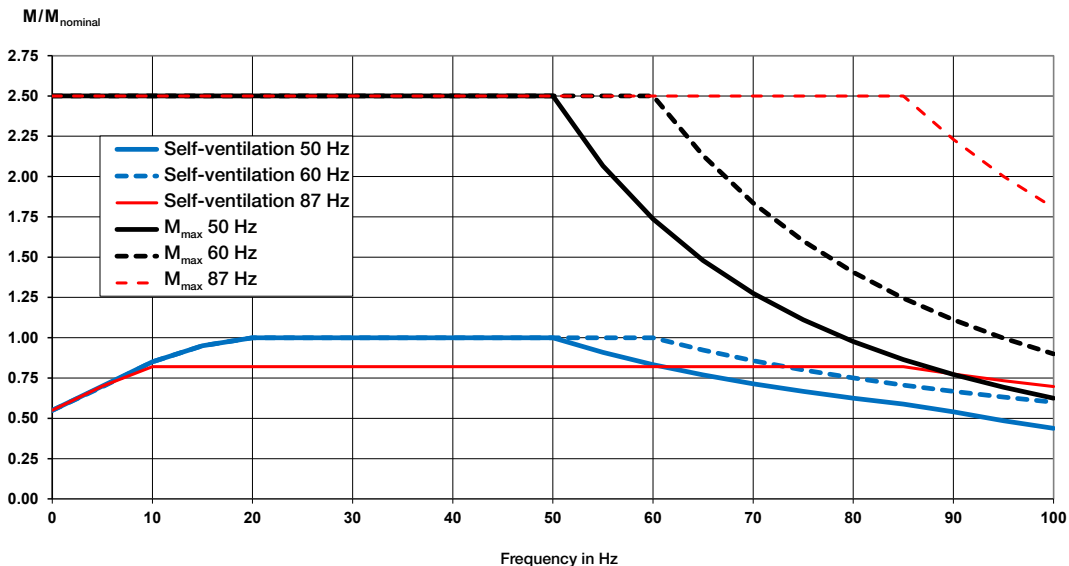

Fig. 5: General thermal limit characteristics of self-ventilated squirrel-cage motors ( $> 7.5$  kW) for 50 Hz, 60 Hz and 87 Hz, plotted alongside the corresponding  $M_{max}$  (pull-out torque) characteristics





**The following side effects must be taken into account in 87 Hz operation:**

- The delta connection subjects the winding insulation to very high voltage stresses
- Disproportionately increased additional motor losses, as a result of which it may be necessary to reduce the rated torque at the 87 Hz operating point by up to 18 %
- Disproportionately increased fan losses
- Increased fan noise (possibly necessitating forced ventilation)
- High bearing stresses (possibly necessitating a relubrication system).
- It may be necessary to use a larger inverter

Notes with regard to the pole numbers and outputs of motors suitable for 87 Hz operation in the standard version:  
 2-pole: Up to 30 kW at 50 Hz (approx. 42 kW at 87 Hz)  
 Limitation: Maximum speed of the standard motor  
 4-pole: Up to 55 kW at 50 Hz (approx. 77 kW at 87 Hz)  
 Dependent on the drive application; a 2-pole motor may be more suitable. Options such as a larger terminal board and larger terminal box, as well as relubrication system, forced ventilation, etc., may be necessary.  
 6-pole: Not meaningful (use instead a 4-pole motor, possibly with 60 Hz special winding)  
 8-pole: Not meaningful and not economical (depending on the application, use instead a 4-pole standard motor or 6-pole motor with 60 Hz special winding)

**Voltage stresses (insulation systems)**

Table 1 shows the insulation systems used by VEM, the maximum permissible pulse voltages  $\hat{U}_{LL}$  and the application possibilities for different mains voltages. The prerequisite where motors are operated without filter at the inverter output is star connection of the windings. Furthermore, the following applies for the different application possibilities:

- x → For inverters with uncontrolled input rectifier  
 → No limitations
- 1 → No regenerative/braking operation
- 2 → No regenerative/braking operation, no use in complex drive systems with central DC link, no voltage boosting with controlled input inverter
- → Motor operation not permissible without filter at the inverter output

Types/series	Standard series		KU.R, KU.-F, WU.R, WU.F		KV.R, KV.F
Insulation system	to Sp2945	Standard	Reinforced KU		Reinforced KV
Sizes	BG ≤ 132 *)	BG ≥ 132 *)	BG ≤ 132 *)	BG ≥ 132 *)	BG ≥ 132
Pulse voltage $\hat{U}_{LL}$	1350 V		1560 V	1800 V	2500 V
<b>Mains voltages</b>					
up to 400 V	x		x		x
up to 440 V	1		x		x
up to 500 V	2		2	x	x
up to 600 V	-		-	2	x
up to 690 V	-		-		x

Table 1: VEM insulation systems for inverter-fed motors  
 \*) see section: Options/Motors

Correlations with regard to voltage stresses at the motor terminals:

- Short motor cable → high rate of voltage rise (du/dt)  
 → low peak voltage  $\hat{U}_{LL}$
- Long motor cable → low rate of voltage rise (du/dt)  
 → high peak voltage  $\hat{U}_{LL}$

The maximum motor cable length is dependent on the inverter output, the voltage level and the cable design (shielded/unshielded). The maximum length for a shielded motor cable is usually only approx. 2/3 of the length of a cable without shielding. As a rough guide, the following ap-

plies with regard to the motor cable length for configurations without filter at the inverter output:

- Inverter output ≤ 4 kW → short motor cable (≤ approx. 35/50 m) shielded/unshielded)
- Inverter output ≥ 22 kW → long motor cable (≥ approx. 100/150 m) shielded/unshielded)

## NAMUR

“User Association for Automation Technology in the Process Industries”

In NAMUR recommendation NE 38, it is proposed that filters should always be provided at the output of an inverter as a means to

- reduce voltage stresses
- minimise harmonic effects and
- suppress electromagnetic interference.

The following values are to be considered suitable limit values:

For 400 V and 500 V motors:

$$\hat{U}_{LL} < 1000 \text{ V and } du/dt < 500 \text{ V}/\mu\text{s}$$

For 690 V motors:

$$\hat{U}_{LL} < 1350 \text{ V and } du/dt < 500 \text{ V}/\mu\text{s}$$

In a drive system configured to comply with **NAMUR** specifications, the motors can be designed with **standard insulation** or **insulation to Sp2945**, irrespective of the mains voltage; a filter is to be provided at the inverter output.

## Bearing stresses (insulated bearings)

Insulated bearings must be used on the non-drive side of inverter-fed motors from size 315. Motors of the KU.. and KV.. series possess insulated bearings as standard from size 315.

Where motors with high pole numbers and standard insulation are used to drive fluid machines, it is sufficient to provide insulated bearings from outputs of 100 kW.

In case of frequent operation at low frequencies ( $f_{mot} < 10 \text{ Hz}$ ) and with high torque, VEM recommends the use of insulated bearings on the non-drive side also with motors of smaller sizes.

Bearing currents can also be reduced by the following measures:

- Use of du/dt or sine-wave filters
- Use of common mode filters
- Good RF earthing between the motor and inverter housing
- Use of symmetrical multi-core motor cables

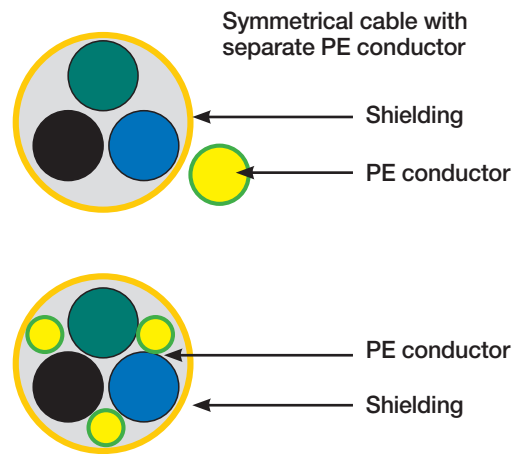

Fig. 6: Symmetrical multi-core motor cables

## Information required for drive specification

For proper specification of a variable-speed drive system, at least the following information is required

- Mains voltage
- Required torque of the working machine over the speed setting range
- Duration of operation at  $f < 20 \text{ Hz}$  (not for quadratically decreasing torque characteristic)

- Overload requirements and times, etc.
- Thermal reserves
- Maximum cooling air temperature, if above  $+40 \text{ }^\circ\text{C}$
- Maximum installation altitude, if more than 1000 m above sea level

## Basic data of inverters

### Mains voltage ranges

Mains voltage ranges: 230 – 480 V +10 %/-15 %  
 (-10 % at 230 V)  
 440 – 525 V +10 %/-15 %  
 (up to 74 A)  
 500 – 690 V +10 %/-15 %  
 (from 90 A)

Mains frequency: 45 to 65 Hz  
 Power factor: 0.95

### Overload capacity and degree of protection

Drives of fluid machines (quadratically increased load torque characteristic) are required to handle only minor overloading. The inverter can be operated with a higher continuous

current than is the case with drives for higher overload requirements. VEMoDRIVE inverters in the SD variant (Standard Dynamic) satisfy such requirements.

Inverters for applications with high overload requirements possess a lower continuous current. The high thermal reserves are required to handle 150 % overload current for 1 minute every 10 minutes.

Inverters are to be selected in accordance with the rated and overload currents (overload torque) rather than the output of the motor. In applications requiring only low dynamic performance where – for whatever reason – the motor must be oversized, the inverter can be selected to match the actual motor current rather than the (higher) current specified on the rating plate.

## Cooling

The inverter output currents specified in the selection tables apply for an ambient temperature of +40 °C. Inverters with IP 54 protection may be operated at higher ambient temperatures if the current is reduced by 2.5 %/°C.

Inverters can be supplied as follows:

380 – 460 V mains connection:  
 up to 250 A → wall-mounted unit, IP 20/21 or IP 54  
 from 300 A → cabinet unit, IP 54  
 480 – 690 V mains connection:  
 up to 200 A → wall-mounted unit, IP 20/21 or IP 54  
 from 250 A → cabinet unit, IP 54

From 300/250 A, modules can also be supplied with IP 20 protection for installation in switch cabinets.

The following maximum ambient temperatures are to be observed:

Inverters up to 74 A: max. +50 °C  
 Inverters from 90 A: max. +45 °C

## Switching frequency

The standard switching frequency for inverters is 3 kHz. Generally speaking, the following applies:

- Increasing frequency (max. 6 kHz)
  - higher inverter losses
  - lower motor losses
  - reduced switching noise at the motor

- Decreasing frequency (min. 1.5 kHz)
  - lower inverter losses
  - higher motor losses
  - increased switching noise, depending on the pulse pattern

## Options

### Motors

#### Insulation systems

##### a) Motor sizes ≤ 112

###### Mains voltage 400 V

Motors in sizes ≤ 112 must not be operated on inverters without output filter unless they have been manufactured according to special drawing Sp2945. The order must specify **Sp2945**.

###### Mains voltage 500 V

For non-certified standard and special motors, a reinforced insulation system is dependent on the design status of the series. This is indicated by way of a “U” after the letter “W” in the selection tables. The motors can be used for drive systems where peak voltages up to 1560 V are to be expected at the motor terminals. The insulation system is an element of the type designation and thus not an option in the proper sense. In the case of certified motors, e.g. marine motors or motors for the North American market, the reinforced insulation system is an option indicated by the additional letters “TU”.

###### Mains voltage 690 V:

It is not permissible to operate motors in sizes ≤ 112 without filter at the inverter output. The type of filter is dependent on the insulation system: Sine-wave filter for a withstand voltage of 1350 V or du/dt filter for a withstand voltage of 1560 V.

##### b) Motor size 132

Motors in size 132 can be manufactured with an insulation system corresponding to either a) or c), depending on the type. If a reinforced insulation system in accordance with c) is required, therefore, it is necessary to submit a separate enquiry.

##### c) Motor sizes ≥ 160

For non-certified standard and special motors in sizes ≥ 160, a reinforced insulation system is similarly dependent on the design status of the series. In the selection tables, this is indicated by way of a “U” for insulation systems up to a peak voltage of 1800 V or a “V” for insulation systems up to a peak voltage of 2500 V. For these motors, the insulation system is an element of the type designation and thus not an option in the proper sense.

In the case of certified motors, e.g. marine motors or motors for the North American market, the reinforced insulation system is an option indicated by the additional letters “TU” for a withstand voltage of 1800 V or “TV” for a withstand voltage of 2500 V.

#### Winding protection

VEM recommends that inverter-fed motors should always be provided with winding protection.

In the case of forced ventilation or motors which must also deliver a high continuous torque at frequencies below 20 Hz, winding protection is imperative.

#### Important:

Motors with reinforced winding insulation incorporate temperature sensors with enhanced dielectric strength (higher price compared to the standard version).

The following options are available as standard for winding protection:

- 3 PTC sensors (TPM) for disconnection or 2 x 3 PTC sensors for warning and disconnection
- Temperature sensor (KTY)
- Resistance thermometer Pt100 (PT)
- Microtherm switch (MT)

## Insulated bearings (IL)

Criteria for use: See section "Bearing stresses (insulated bearings)"

## Relubrication system (NS)

Motors in sizes from 315 MX are supplied with a relubrication system as standard. A relubrication system can be supplied as an option for motors in sizes from 132 (except 132 T) to 315 M at extra cost.

Where the operating speed of a motor lies significantly above the rated speed or else the motor is to be operated in high ambient temperatures, a relubrication system may be expedient also for smaller shaft heights.

## Encoders

The following incremental encoders are standard options:

- BaumerThalheim ITD 2. up to size 80
- BaumerThalheim ITD 4. up to size 132 T
- Leine & Linde 861 from size 132

Where the motor is fitted with an insulated bearing, either an insulated encoder must be used (extra cost) or else the standard encoder must be mounted with corresponding insulation.

## Forced ventilation (or water cooling)

Forced ventilation is an element of the type designation for surface-cooled motors and is thus not marked separately. Forced ventilation fans from Wistro are used as standard for all motor sizes. They are used above all where an otherwise self-ventilated motor is planned for

- operation at frequencies below 20 Hz and with high torques in continuous operation, or
- operation at speeds far in excess of the rated speed where a required maximum noise level cannot be observed with self-ventilation.

Water-cooled motors are a separate design variant and can be supplied from size 225.

## Brake

A Stromag brake can be mounted on all motors specified in the selection tables. To enable verification of intended application, it is recommended to specify the required holding or braking torque in the order. If necessary, the rectifier can be installed in the terminal box.

## Cable entry

On motors from size 250, the number and diameters of the cable entries must be compared with the requirements of the application. The number of cables specified in the selection tables corresponds to the number of terminal studs in the inverters. It should be noted that the recommended cable cross-section represents the permissible maximum for most high-current inverters.

## Cable glands

If screwed cable glands are not specified, EMC-compliant types are to be used with inverter-fed motors.

## Inverters

### Standard options

Field bus and Ethernet modules

- Profibus
- DeviceNet
- Modbus/TCP
- EtherCAT
- Profinet IO 1-port
- Profinet IO 2-port

Additional boards

- I/O board
- Encoder board
- PTC/Pt100 board
- CRIO board
- RS232/RS485 isolated

Coated boards

### Factory options

- External voltage supply
- Safe stop
- Brake chopper
- EMC filter class C2
- PTC

### Operating units

- Handheld operating unit
- External operating unit IP 54 for mounting in a cabinet door
- Dummy plate as mounting support for external operating unit

### Additional options

- Output reactors
- Sine-wave filters
- Brake resistors

## Technical data/selection tables

The selection tables contain suggestions as to which motors and inverters can be combined to form a VEMoDRIVE Single drive system. The drives are grouped according to the mains voltages 400 V, 500 V and 690 V.

### Motors

Insulation systems are assigned to the individual mains voltages 400 V, 500 V and 690 V.

- 400 V mains: Insulation according to Sp2945 and standard insulation ( $\dot{U}_{LL}$  up to 1350 V)  
Operation without output filter is permissible
- 500 V mains: Reinforced (KU) insulation ( $\dot{U}_{LL}$  up to 1560/1800 V)  
Operation without output filter is permissible
- 690 V mains: a) Reinforced (KU) insulation ( $\dot{U}_{LL}$  up to 1560/1800 V)  
Operation only permissible with du/dt filter
- b) Reinforced (KV) insulation ( $\dot{U}_{LL}$  up to 2500 V)  
Operation without output filter is permissible

The motors with standard and KU insulation are energy-saving motors with classification to efficiency class IE2. Motors with KV insulation are manufactured solely for inverter-fed operation. Due to their deviating size-output rating assignments, they are reserved for particular applications and are thus not classified.

It is also possible to supply 8-pole IE2 and IE3 motors and unclassified motors with higher numbers of poles. The available variants can be taken from the VEM Electronic Catalogue ( **VEM** **eKAT**<sup>V10</sup> ).

### Inverters

Each motor can be incorporated into either of two drive systems, which differ in terms of the torque characteristics of the working machine and the overload capacity of the inverter. The available inverter variants are designated Standard Dynamic (SD) and High-Dynamic (HD).

#### Overload capacity 120 %:

Fluid machines place no great demands on the overload capacity of the drive unit. The high degree of utilisation of the thermal capacity of the inverter permits a high continuous current. Such applications are the principal domain of inverters in the SD variant. The inverter size is determined by the rated current of the motor rather than the rated output. Thermal overloading of the motor at lower speed can usually be excluded on account of the quadratically decreasing torque characteristic of the fluid machine.

#### Overload 150 %:

Inverters for drives with high overload requirements must possess high thermal reserves. For this reason, it is generally necessary to use an inverter with a higher current than is the case for a fluid machine.

For simple applications, it is still possible to use a VEMoDRIVE inverter in the SD variant. Where high demands are placed on the dynamic performance of the motor and where constant torques and speeds are important, however, it is necessary to select a VEMoDRIVE inverter in the HD variant.

#### Important:

Not all SD inverters can be upgraded to produce an HD inverter.

Depending on the voltage level, inverters up to 250 A or 200 A are available as wall-mounted units, those for higher currents as modules (IP 20) or cabinet units.

Higher outputs than those specified in the tables can be supplied by special request.

## Technical data/selection tables

with self-ventilated 2-pole energy-saving motors for normal operation (overload 120 %, 1 minute every 10 minutes)

IE2 motors (for 50 Hz mains operation) for the output range from 0.09 kW to 500 kW

IE3 motors (for 50 Hz mains operation) for the output range from 560 to 710 kW (size 400)

Mains voltage: 400 V

Type designation	Mains operation 50 Hz				Inverter-fed operation 50 Hz			Maximum speed for P = constant	Inverter	Current	Recommended cross-sections for motor connection cable
	Rated motor output	Rated motor speed	Rated motor torque	Rated motor current	Motor output	Motor torque	Motor current				
$\hat{U}_{LL} \leq 1350$ V	P/kW	n/rpm	M/Nm	A (400 V)	P/kW	M/Nm	A (400 V)	rpm		A	mm <sup>2</sup>
IE2-W21R 56 K2	0.09	2825	0.3	0.22	0.09	0.3	0.22	6000	A		
IE2-W21R 56 G2	0.12	2810	0.41	0.31	0.12	0.41	0.31	6000	A		
IE2-W21R 63 K2	0.18	2840	0.61	0.42	0.18	0.61	0.42	6000	A		
IE2-W21R 63 G2	0.25	2860	0.83	0.55	0.25	0.83	0.55	6000	A		
IE2-W21R 71 K2	0.37	2860	1.24	0.78	0.37	1.24	0.78	6000	A		
IE2-W21R 71 G2	0.55	2870	1.83	1.1	0.55	1.83	1.1	6000	A		
IE2-W21R 80 K2	0.75	2880	2.49	1.5	0.75	2.49	1.5	6000	VSI2.0WSA1-4/0003A	2.5	3 x 1.5 + 3G0.25
IE2-WE1R 80 G2	1.1	2885	3.64	2.2	1.1	3.64	2.2	6000	VSI2.0WSA1-4/0003A	2.5	3 x 1.5 + 3G0.25
IE2-WE1R 90 S2	1.5	2910	4.92	2.9	1.5	4.92	2.9	6000	VSI2.0WSA1-4/0004A	4	3 x 1.5 + 3G0.25
IE2-WE1R 90 L2	2.2	2880	7.29	4.3	2.2	7.29	4.3	6000	VSI2.0WSA1-4/0006A	6	3 x 1.5 + 3G0.25
IE2-WE1R 100 L2	3	2930	9.78	6.6	3	9.78	6.6	6000	VSI2.0WSA1-4/0008A	7.5	3 x 1.5 + 3G0.25
IE2-WE1R 112 MX2	4	2920	13.08	7.9	4	13.08	7.9	6000	VSI2.0WSA1-4/0010A	9.5	3 x 1.5 + 3G0.25
IE2-WE1R 112 MV2	5.5	2900	18.11	10.3	5.5	18.11	10.3	6000	VSI2.0WSA1-4/0013A	13	3 x 2.5 + 3G0.5
IE2-WE1R 132 S2T	5.5	2900	18.1	10.3	5.5	18.1	10.3	6000	VSI2.0WSA1-4/0013A	13	3 x 2.5 + 3G0.5
IE2-WE1R 132 S2	5.5	2915	18	10.5	5.5	18	10.5	6000	VSI2.0WSA1-4/0013A	13	3 x 2.5 + 3G0.5
IE2-WE1R 132 SX2	7.5	2925	24.5	13.5	7.5	24.5	13.5	6000	VSI2.0WSA1-4/0018A	18	3 x 4 + 3G0.75
IE2-WE1R 160 M2	11	2950	35.6	20	11	35.6	20	6000	VSI2.0WSA1-4/0026A	26	3 x 6 + 3G1
IE2-WE1R 160 MX2	15	2940	48.7	26	15	48.7	26	6000	VSI2.0WSA1-4/0026A	26	3 x 6 + 3G1
IE2-WE1R 160 L2	18.5	2935	60.2	32	18.5	60.2	32	6000	VSI2.0WSA1-4/0037A	37	3 x 10 + 3G1.5
IE2-WE1R 180 M2	22	2935	72	39	22	72	39	5400	VSI2.0WSA1-4/0046A	46	3 x 16 + 3G2.5
IE2-W21R 200 L2	30	2945	97	52	30	97	52	6000	VSI2.0WSA1-4/0061A	61	3 x 25 + 3G4
IE2-WE2R 200 LX2	37	2955	120	64	37	120	64	6000	VSI2.0WSA1-4/0074A	74	3 x 35 + 3G6
IE2-WE1R 225 M2	45	2950	146	81	45	146	81	5000	VSI2.0WSA1-4/0090A	90	3 x 50 + 3G10
IE2-WE1R 250 M2	55	2955	178	96	55	178	96	4500	VSI2.0WSA1-4/0109A	109	3 x 70 + 3G10
IE2-WE1R 280 S2	75	2970	241	128	75	241	128	4300	VSI2.0WSA1-4/0146A	146	3 x 95 + 3G16
IE2-WE1R 280 M2	90	2970	289	151	90	289	151	4300	VSI2.0WSA1-4/0175A	175	3 x 120 + 3G16
IE2-W21R 315 S2	110	2975	353	189	110	353	189	3800	VSI2.0WSA1-4/0210A	210	3 x 185 + 3G35
IE2-W21R 315 M2	132	2975	424	225	132	424	225	3800	VSI2.0WSA1-4/0250A	250	3 x 240 + 3G50
IE2-W21R 315 MX2	160	2973	514	274	160	514	274	3600	VSI2.0CSA1-4/0300A	300	2 x (3 x 95 + 3G16)
IE2-W21R 315 MY2	200	2983	640	344	200	640	344	3600	VSI2.0CSA1-4/0375A	375	2 x (3 x 150 + 3G25)
IE2-W21R 315 L2	250	2984	800	411	220	704	356	3600	VSI2.0CSA1-4/0375A	375	2 x (3 x 150 + 3G25)
IE2-W21R 315 LX2	315	2985	1008	518	270	864	438	3600	VSI2.0CSA1-4/0500A	500	2 x (3 x 240 + 3G35)
IE2-W22R 355 MY2	315	2988	1008	534	315	1008	500	3600	VSI2.0CSA1-4/0500A	500	2 x (3 x 240 + 3G35)
IE2-W22R 355 M2	355	2985	1136	583	330	1056	542	3600	VSI2.0CSA1-4/0600A	600	3 x (3 x 150 + 3G25)
IE2-W22R 355 MX2	400	2990	1278	664	355	1134	588	3600	VSI2.0CSA1-4/0600A	600	3 x (3 x 150 + 3G25)
IE2-W22R 355 LY2	450	2985	1440	739	425	1360	700	3600	VSI2.0CSA1-4/0750A	750	3 x (3 x 240 + 3G50)
IE2-W22R 355 L2	500	2990	1597	821	425	1357	700	3600	VSI2.0CSA1-4/0750A	750	3 x (3 x 240 + 3G50)
<b>IE3</b>											
IE3-W42R 400 M2	560	2988	1790	965	A	A	A	A	VSI2.0CSA1-4/1000A	1000	4 x (3 x 240 + 3G50)
IE3-W42R 400 MX2	630	2988	2014	1070	A	A	A	A	VSI2.0CSA1-4/1000A	1000	4 x (3 x 240 + 3G50)
IE3-W42R 400 L2	710	2988	2269	1195	A	A	A	A	VSI2.0CSA1-4/1150A	1150	5 x (3 x 185 + 3G35)

Insulation to Sp2945

... 1-: Standard Dynamic (SD)

A = by request

Motor sizes > 400 by request

All motors can be supplied with optional forced ventilation at additional cost.

The "R" (rib-cooled with self-ventilation) in the type designation is to be replaced with "F" (forced ventilation).

## Technical data/selection tables

with self-ventilated 2-pole energy-saving motors for heavy duty (overload 150 %, 1 minute every 10 minutes)

IE2 motors (for 50 Hz mains operation) for the output range from 0.09 kW to 500 kW

IE3 motors (for 50 Hz mains operation) for the output range from 560 to 710 kW (size 400)

Mains voltage: 400 V

Type designation	Mains operation 50 Hz				Inverter-fed operation							Mechanical limit speed	Maximum speed for P = constant	Inverter	Current	Recommended cross-sections for motor connection cable	
	P/kW	n/rpm	M/Nm	A (400 V)	P/kW	M/Nm	P/kW	M/Nm	P/kW	M/Nm	P/kW						M/Nm
Control range					1:2.5	1:5	1:10										
Speed range					1200 – 3000 rpm		600 – 3000 rpm		300 – 3000 rpm								
	Rated motor output	Rated motor speed	Rated motor torque	Rated motor current	Motor output	Motor torque	Motor output	Motor torque	Motor output	Motor torque	Motor output	Motor torque	Motor current by 400 V	Type			
U <sub>LL</sub> ≤ 1350 V	P/kW	n/rpm	M/Nm	A (400 V)	P/kW	M/Nm	P/kW	M/Nm	P/kW	M/Nm	P/kW	M/Nm	A	rpm	rpm	A	mm <sup>2</sup>
IE2-W21R 56 K2	0.09	2825	0.3	0.22	0.09	0.3	0.09	0.3	0.07	0.24	0.22	15000	6000	A			
IE2-W21R 56 G2	0.12	2810	0.41	0.31	0.12	0.41	0.12	0.41	0.1	0.33	0.31	15000	6000	A			
IE2-W21R 63 K2	0.18	2840	0.61	0.42	0.18	0.61	0.18	0.61	0.14	0.5	0.42	15000	6000	A			
IE2-W21R 63 G2	0.25	2860	0.83	0.55	0.25	0.83	0.25	0.83	0.2	0.66	0.55	15000	6000	A			
IE2-W21R 71 K2	0.37	2860	1.24	0.78	0.37	1.24	0.37	1.24	0.3	1	0.78	14000	6000	A			
IE2-W21R 71 G2	0.55	2870	1.83	1.1	0.55	1.83	0.55	1.83	0.44	1.46	1.1	14000	6000	A			
IE2-W21R 80 K2	0.75	2880	2.49	1.5	0.75	2.49	0.75	2.49	0.6	1.99	1.5	13000	6000	VSI2.0WSA_-4/0003A	2	3 x 1.5 + 3G0.25	
IE2-WE1R 80 G2	1.1	2885	3.64	2.2	1.1	3.64	1.1	3.64	0.9	2.98	2.2	13000	6000	VSI2.0WSA_-4/0004A	3.2	3 x 1.5 + 3G0.25	
IE2-WE1R 90 S2	1.5	2910	4.92	2.9	1.5	4.92	1.5	4.92	1.2	3.94	2.9	11000	6000	VSI2.0WSA_-4/0004A	3.2	3 x 1.5 + 3G0.25	
IE2-WE1R 90 L2	2.2	2880	7.29	4.3	2.2	7.29	2.2	7.29	1.8	5.97	4.3	11000	6000	VSI2.0WSA_-4/0008A	6	3 x 1.5 + 3G0.25	
IE2-WE1R 100 L2	3	2930	9.78	6.6	3	9.78	3	9.78	2.4	7.88	6.6	10000	6000	VSI2.0WSA_-4/0010A	7.6	3 x 1.5 + 3G0.25	
IE2-WE1R 112 MX2	4	2920	13.08	7.9	4	13.08	4	13.08	3.2	10.5	7.9	7000	6000	VSI2.0WSA_-4/0013A	10.4	3 x 2.5 + 3G0.5	
IE2-WE1R 112 MV2	5.5	2900	18.11	10.3	5.5	18.11	5.5	18.11	4.4	14.5	10.3	7000	6000	VSI2.0WSA_-4/0013A	10.4	3 x 2.5 + 3G0.5	
IE2-WE1R 132 S2T	5.5	2900	18.1	10.3	5.5	18.1	5.5	18.1	4.4	14.5	10.3	7000	6000	VSI2.0WSA_-4/0013A	10.4	3 x 2.5 + 3G0.5	
IE2-WE1R 132 S2	5.5	2915	18	10.5	5.5	18	5.5	18	5.2	17	10.5	7000	6000	VSI2.0WSA_-4/0013A	10.4	3 x 2.5 + 3G0.5	
IE2-WE1R 132 SX2	7.5	2925	24.5	13.5	7.5	24	7.5	24	7.1	23	13.5	7000	6000	VSI2.0WSA_-4/0018A	14.4	3 x 4 + 3G0.75	
IE2-WE1R 160 M2	11	2950	35.6	20	11	36	11	36	10.5	34	20	7000	6000	VSI2.0WSA_-4/0026A	21	3 x 6 + 3G1	
IE2-WE1R 160 MX2	15	2940	48.7	26	15	49	15	49	14.3	46	26	6000	6000	VSI2.0WSA_-4/0037A	29.6	3 x 10 + 3G1.5	
IE2-WE1R 160 L2	18.5	2935	60.2	32	18.5	60	18.5	60	17.6	57	32	6000	6000	VSI2.0WSA_-4/0046A	37	3 x 16 + 3G2.5	
IE2-WE1R 180 M2	22	2935	72	39	22	72	22	72	20.9	68	39	6000	5400	VSI2.0WSA_-4/0061A	49	3 x 25 + 3G4	
IE2-WE1R 200 L2	30	2945	97	52	30	97	30	97	28.5	92	52	6000	6000	VSI2.0WSA_-4/0074A	59	3 x 35 + 3G6	
IE2-WE2R 200 LX2	37	2955	120	64	37	120	37	120	35.2	114	64	6000	6000	VSI2.0WSA_-4/0090A	72	3 x 50 + 3G6	
IE2-WE1R 225 M2	45	2950	146	81	45	146	45	146	42.8	139	81	5000	5000	VSI2.0WSA_-4/0109A	87	3 x 70 + 3G10	
IE2-WE1R 250 M2	55	2955	178	96	55	178	55	178	52.3	169	96	4500	4500	VSI2.0WSA_-4/0146A	117	3 x 95 + 3G16	
IE2-WE1R 280 S2	75	2970	241	128	75	241	75	241	71.3	229	128	4300	4300	VSI2.0WSA_-4/0175A	140	3 x 120 + 3G16	
IE2-WE1R 280 M2	90	2970	289	151	90	289	90	289	85.5	275	151	4300	4300	VSI2.0WSA_-4/0210A	168	3 x 185 + 3G35	
IE2-W21R 315 S2	110	2975	353	189	110	353	110	353	105	335	189	3800	3800	VSI2.0WSA_-4/0250A	200	3 x 240 + 3G50	
IE2-W21R 315 M2	132	2975	424	225	132	424	132	424	125	403	225	3800	3800	VSI2.0CSA_-4/0300A	240	2 x (3 x 95 + 3G15)	
IE2-W21R 315 MX2	160	2973	514	274	160	514	160	514	152	488	274	3600	3600	VSI2.0CSA_-4/0375A	300	2 x (3 x 150 + 3G25)	
IE2-W21R 315 MY2	200	2983	640	344	192	615	192	615	190	608	344	3600	3600	VSI2.0CSA_-4/0430A	344	2 x (3 x 185 + 3G35)	
IE2-W21R 315 L2	250	2984	800	411	220	704	220	704	209	669	356	3600	3600	VSI2.0CSA_-4/0500A	400	2 x (3 x 240 + 3G35)	
IE2-W21R 315 LX2	315	2985	1008	518	270	864	270	864	257	821	438	3600	3600	VSI2.0CSA_-4/0600A	480	3 x (3 x 150 + 3G25)	
IE2-W22R 355 MY2	315	2988	1008	534	315	1007	315	1007	299	957	500	3600	3600	VSI2.0CSA_-4/0650A	520	3 x (3 x 185 + 3G35)	
IE2-W22R 355 M2	355	2985	1136	583	330	1056	330	1056	314	1003	542	3600	3600	VSI2.0CSA_-4/0750A	600	3 x (3 x 240 + 3G50)	
IE2-W22R 355 MX2	400	2990	1278	664	355	1134	355	1134	337	1077	588	3600	3600	VSI2.0CSA_-4/0750A	600	3 x (3 x 240 + 3G50)	
IE2-W22R 355 LY2	450	2985	1440	739	370	1184	370	1184	370	1184	700	3600	3600	VSI2.0CSA_-4/0860A	688	4 x (3 x 185 + 3G35)	
IE2-W22R 355 L2	500	2990	1597	821	370	1182	370	1182	370	1182	700	3600	3600	VSI2.0CSA_-4/0860A	688	4 x (3 x 185 + 3G35)	
<b>IE3</b>																	
IE3-W42R 400 M2	560	2988	1790	965	A	A	A	A	A	A	A	A	A	VSI2.0CSA_-4/1250A	1000	5 x (3 x 240 + 3G50)	
IE3-W42R 400 MX2	630	2988	2014	1070	A	A	A	A	A	A	A	A	A	VSI2.0CSA_-4/1350A	1080	6 x (3 x 185 + 3G35)	
IE3-W42R 400 L2	710	2988	2269	1195	A	A	A	A	A	A	A	A	A	VSI2.0CSA_-4/1500A	1200	6 x (3 x 240 + 3G50)	

Insulation to Sp2945

A = by request

Motor sizes > 400 by request

All motors can be supplied with optional forced ventilation at additional cost.

The "R" (rib-cooled with self-ventilation) in the type designation is to be replaced with "F" (forced ventilation).

depending on requirements

... 1-: Standard Dynamic (SD) or

... 2-: High Dynamic (HD)

## Technical data/selection tables

with self-ventilated 4-pole energy-saving motors for normal operation (overload 120 %, 1 minute every 10 minutes)

IE2 motors (for 50 Hz mains operation) for the output range from 0.06 kW to 500 kW

IE3 motors (for 50 Hz mains operation) for the output range from 560 to 710 kW (size 400)

Mains voltage: 400 V

Type designation	Mains operation 50 Hz				Inverter-fed operation 50 Hz			Maximum speed for P = constant	Inverter	Current	Recommended cross-sections for motor connection cable
	Rated motor output	Rated motor speed	Rated motor torque	Rated motor current	Motor output	Motor torque	Motor current				
$\hat{U}_{LL} \leq 1350$ V	P/kW	n/rpm	M/Nm	A (400 V)	P/kW	M/Nm	A (400 V)	rpm		A	mm <sup>2</sup>
IE2-W21R 56 K4	0.06	1400	0.41	0.20	0.06	0.41	0.20	3000	A		
IE2-W21R 56 G4	0.09	1370	0.63	0.28	0.09	0.63	0.28	3000	A		
IE2-W21R 63 K4	0.12	1400	0.82	0.35	0.12	0.82	0.35	3000	A		
IE2-W21R 63 G4	0.18	1425	1.21	0.57	0.18	1.21	0.57	3000	A		
IE2-W21R 71 K4	0.25	1430	1.67	0.66	0.25	1.67	0.66	3000	A		
IE2-W21R 71 G4	0.37	1430	2.47	0.98	0.37	2.47	0.98	3000	A		
IE2-W21R 80 K4	0.55	1430	3.67	1.25	0.55	3.67	1.25	3000	A		
IE2-W21R 80 G4	0.75	1430	5.0	1.65	0.75	5.01	1.65	3000	VSI2.0WSA1-4/0003A	2.5	3 x 1.5 + 3G0.25
IE2-WE1R 90 S4	1.1	1435	7.3	2.42	1.1	7.32	2.42	3000	VSI2.0WSA1-4/0003A	2.5	3 x 1.5 + 3G0.25
IE2-WE1R 90 L4	1.5	1445	9.9	3.35	1.5	9.91	3.35	3000	VSI2.0WSA1-4/0004A	4	3 x 1.5 + 3G0.25
IE2-WE1R 100 L4	2.2	1455	14.4	4.8	2.2	14.4	4.8	3000	VSI2.0WSA1-4/0006A	6	3 x 1.5 + 3G0.25
IE2-WE1R 100 LX4	3	1455	19.7	6.5	3	19.7	6.5	3000	VSI2.0WSA1-4/0008A	7.5	3 x 1.5 + 3G0.25
IE2-WE1R 112 MZ4	4	1445	26.4	8.3	4	26.4	8.3	3000	VSI2.0WSA1-4/0010A	9.5	3 x 1.5 + 3G0.25
IE2-WE1R 112 M4	4	1460	26.2	7.6	4	26.2	7.7	3000	VSI2.0WSA1-4/0010A	9.5	3 x 1.5 + 3G0.25
IE2-WE1R 132 S4	5.5	1470	35.7	10	5.5	35.7	10	3000	VSI2.0WSA1-4/0013A	13	3 x 2.5 + 3G0.5
IE2-WE2R 132 S4	5.5	1450	36.2	10.5	5.5	36.2	10.5	3000	VSI2.0WSA1-4/0013A	13	3 x 2.5 + 3G0.5
IE2-WE1R 132 M4	7.5	1470	48.7	14.5	7.5	48.7	14.5	3000	VSI2.0WSA1-4/0018A	18	3 x 4 + 3G0.75
IE2-WE1R 160 M4	11	1475	71	21.5	11	71	21.5	3000	VSI2.0WSA1-4/0026A	26	3 x 6 + 3G1
IE2-WE2R 160 L4	15	1480	97	28	15	97	28	3000	VSI2.0WSA1-4/0031A	31	3 x 10 + 3G1.5
IE2-WE1R 180 M4	18.5	1475	120	34	18.5	120	34	3000	VSI2.0WSA1-4/0037A	37	3 x 10 + 3G1.5
IE2-WE1R 180 L4	22	1475	142	42	22	142	42	3000	VSI2.0WSA1-4/0046A	46	3 x 16 + 3G2.5
IE2-WE1R 200 L4	30	1480	194	58.5	30	194	58.5	3000	VSI2.0WSA1-4/0061A	61	3 x 25 + 3G4
IE2-WE1R 225 S4	37	1475	240	68.5	37	240	68.5	3000	VSI2.0WSA1-4/0074A	74	3 x 35 + 3G6
IE2-WE1R 225 M4	45	1483	290	83	45	290	83	2600	VSI2.0WSA1-4/0090A	90	3 x 50 + 3G10
IE2-WE1R 250 M4	55	1485	354	101	55	354	101	2600	VSI2.0WSA1-4/0109A	109	3 x 70 + 3G10
IE2-WE1R 280 S4	75	1485	482	137	75	482	137	2400	VSI2.0WSA1-4/0146A	146	3 x 95 + 3G16
IE2-WE1R 280 M4	90	1483	580	164	90	580	164	2600	VSI2.0WSA1-4/0175A	175	3 x 120 + 3G16
IE2-W21R 315 S4	110	1485	707	204	110	707	204	3000	VSI2.0WSA1-4/0210A	210	3 x 185 + 3G35
IE2-W21R 315 M4	132	1484	849	242	132	849	242	2600	VSI2.0WSA1-4/0250A	250	3 x 240 + 3G50
IE2-W21R 315 MX4	160	1482	1031	289	160	1031	289	2500	VSI2.0CSA1-4/0300A	300	2 x (3 x 95 + 3G16)
IE2-W21R 315 MY4	200	1490	1282	349	200	1282	342	2800	VSI2.0CSA1-4/0375A	375	2 x (3 x 150 + 3G25)
IE2-W21R 315 L4	250	1490	1602	430	250	1608	417	3000	VSI2.0CSA1-4/0430A	430	2 x (3 x 185 + 3G35)
IE2-W21R 315 LX4	315	1490	2019	542	285	1827	484	3000	VSI2.0CSA1-4/0500A	500	2 x (3 x 240 + 3G35)
IE2-W22R 355 MY4	315	1491	2019	560	315	2019	560	3000	VSI2.0CSA1-4/0600A	600	3 x (3 x 150 + 3G25)
IE2-W22R 355 M4	355	1493	2271	617	355	2271	630	3000	VSI2.0CSA1-4/0650A	650	3 x (3 x 185 + 3G35)
IE2-W22R 355 MX4	400	1494	2557	687	390	2493	692	3000	VSI2.0CSA1-4/0750A	750	3 x (3 x 240 + 3G50)
IE2-W22R 355 L4	500	1493	3198	900	410	2622	775	3000	VSI2.0CSA1-4/0860A	860	4 x (3 x 185 + 3G35)
<b>IE3</b>											
IE3-W42R 400 M4	560	1493	3582	1006	A	A	A	A	VSI2.0CSA1-4/1000A	1000	4 x (3 x 240 + 3G50)
IE3-W42R 400 MX4	630	1493	4030	1119	A	A	A	A	VSI2.0CSA1-4/1150A	1150	5 x (3 x 185 + 3G35)
IE3-W42R 400 L4	710	1493	4542	1261	A	A	A	A	VSI2.0CSA1-4/1150A	1150	5 x (3 x 185 + 3G35)

Insulation to Sp2945

... 1-: Standard Dynamic (SD)

A = by request

Motor sizes > 400 by request

All motors can be supplied with optional forced ventilation at additional cost.

The "R" (rib-cooled with self-ventilation) in the type designation is to be replaced with "F" (forced ventilation).



## Technical data/selection tables

with self-ventilated 4-pole energy-saving motors for heavy duty (overload 150 %, 1 minute every 10 minutes)

IE2 motors (for 50 Hz mains operation) for the output range from 0.06 kW to 500 kW

IE3 motors (for 50 Hz mains operation) for the output range from 560 to 710 kW (size 400)

Mains voltage: 400 V

Type designation	Mains operation 50 Hz				Inverter-fed operation							Mechanical limit speed	Maximum speed for P = constant	Inverter	Current	Recommended cross-sections for motor connection cable
	Control range	Speed range	Rated motor output	Rated motor speed	Rated motor torque	Rated motor current	Motor output	Motor torque	Motor output	Motor torque	Motor output					
U <sub>LL</sub> ≤ 1350 V	P/kW	n/rpm	M/Nm	A	P/kW	M/Nm	P/kW	M/Nm	P/kW	M/Nm	A	rpm	rpm	A	mm <sup>2</sup>	
IE2-W21R 56 K4	0.06	1400	0.41	0.20	0.06	0.41	0.06	0.41	0.05	0.33	0.20	12000	3000	A		
IE2-W21R 56 G4	0.09	1370	0.63	0.28	0.09	0.63	0.09	0.63	0.07	0.50	0.28	12000	3000	A		
IE2-W21R 63 K4	0.12	1400	0.82	0.35	0.12	0.82	0.12	0.82	0.09	0.65	0.35	12000	3000	A		
IE2-W21R 63 G4	0.18	1425	1.21	0.57	0.18	1.21	0.18	1.21	0.14	0.97	0.57	12000	3000	A		
IE2-W21R 71 K4	0.25	1430	1.67	0.66	0.25	1.67	0.25	1.67	0.2	1.34	0.66	11000	3000	A		
IE2-W21R 71 G4	0.37	1430	2.47	0.98	0.37	2.47	0.37	3.47	0.3	2.00	0.98	11000	3000	A		
IE2-W21R 80 K4	0.55	1430	3.67	1.25	0.55	3.67	0.55	3.67	0.44	2.94	1.25	11000	3000	A		
IE2-W21R 80 G4	0.75	1430	5.0	1.65	0.75	5.01	0.75	5.01	0.6	4.01	1.65	11000	3000	VSI2.0WSA_-4/0003A	2.0 3 x 1.5 + 3G0.25	
IE2-WE1R 90 S4	1.1	1435	7.3	2.42	1.10	7.32	1.1	7.32	0.9	5.99	2.42	9000	3000	VSI2.0WSA_-4/0004A	3.2 3 x 1.5 + 3G0.25	
IE2-WE1R 90 L4	1.5	1445	9.9	3.35	1.5	9.9	1.5	9.91	1.2	7.9	3.35	9000	3000	VSI2.0WSA_-4/0006A	4.8 3 x 1.5 + 3G0.25	
IE2-WE1R 100 L4	2.2	1455	14.4	4.8	2.2	14.4	2.2	14.44	1.8	11.8	4.8	8000	3000	VSI2.0WSA_-4/0006A	4.8 3 x 1.5 + 3G0.25	
IE2-WE1R 100 LX4	3	1455	19.7	6.5	3	19.7	3	19.7	2.4	15.8	6.5	6000	3000	VSI2.0WSA_-4/0010A	7.6 3 x 1.5 + 3G0.25	
IE2-WE1R 112 MZ4	4	1445	26.4	8.3	4	26.4	4	26.4	3.2	21	8.3	6000	3000	VSI2.0WSA_-4/0013A	10.4 3 x 2.5 + 3G0.5	
IE2-WE1R 112 M4	4	1460	26.2	7.6	4	26	3.7	24	3.8	25	7.7	6000	3000	VSI2.0WSA_-4/0013A	10.4 3 x 2.5 + 3G0.5	
IE2-WE1R 132 S4	5.5	1470	35.7	10	5.5	36	5.5	36	5.2	34	10.0	3600	3000	VSI2.0WSA_-4/0013A	10.4 3 x 2.5 + 3G0.5	
IE2-WE2R 132 S4	5.5	1450	36.2	10.5	5.5	36	5	33	5.2	34	10.5	3600	3000	VSI2.0WSA_-4/0013A	10.4 3 x 2.5 + 3G0.5	
IE2-WE1R 132 M4	7.5	1470	48.7	14.5	7.5	49	7.5	49	7.1	46	14.5	3600	3000	VSI2.0WSA_-4/0018A	14.4 3 x 4 + 3G0.75	
IE2-WE1R 160 M4	11	1475	71	21.5	11	71	11	71	10.5	68	21.5	3600	3000	VSI2.0WSA_-4/0026A	21 3 x 6 + 3G1	
IE2-WE2R 160 L4	15	1480	97	28	15	97	15	97	14.3	92	28	3600	3000	VSI2.0WSA_-4/0037A	29.6 3 x 10 + 3G1.5	
IE2-WE1R 180 M4	18.5	1475	120	34	18.5	120	18.5	120	17.6	114	34	3000	3000	VSI2.0WSA_-4/0046A	37 3 x 16 + 3G2.6	
IE2-WE1R 180 L4	22	1475	142	42	22	142	22	142	20.9	135	42	3000	3000	VSI2.0WSA_-4/0061A	49 3 x 25 + 3G4	
IE2-WE1R 200 L4	30	1480	194	58.5	30	194	30	194	28.5	184	58.5	3000	3000	VSI2.0WSA_-4/0074A	59 3 x 35 + 3G6	
IE2-WE1R 225 S4	37	1475	240	68.5	37	240	37	240	35.2	228	68.5	3000	3000	VSI2.0WSA_-4/0090A	72 3 x 50 + 3G6	
IE2-WE1R 225 M4	45	1483	290	83	45	290	45	290	42.8	276	83	3000	2600	VSI2.0WSA_-4/0109A	87 3 x 70 + 3G10	
IE2-WE1R 250 M4	55	1485	354	101	55	354	55	354	52.3	336	101	3000	2600	VSI2.0WSA_-4/0146A	117 3 x 95 + 3G16	
IE2-WE1R 280 S4	75	1485	482	137	75	482	75	482	71.3	459	137	3000	2400	VSI2.0WSA_-4/0175A	140 3 x 120 + 3G16	
IE2-WE1R 280 M4	90	1483	580	164	90	580	90	580	85.5	551	164	3000	2600	VSI2.0WSA_-4/0210A	168 3 x 185 + 3G35	
IE2-W21R 315 S4	110	1485	707	204	110	707	110	707	105	672	204	3000	3000	VSI2.0WSA_-4/0250A	200 3 x 240 + 3G50	
IE2-W21R 315 M4	132	1484	849	242	132	849	132	849	125	807	242	3000	2600	VSI2.0CSA_-4/0300A	240 2 x (3 x 95 + 3G15)	
IE2-W21R 315 MX4	160	1482	1031	289	160	1031	160	1031	152	979	289	3000	2500	VSI2.0CSA_-4/0375A	300 2 x (3 x 150 + 3G25)	
IE2-W21R 315 MY4	200	1490	1282	349	200	1282	200	1282	190	1218	342	3000	2800	VSI2.0CSA_-4/0430A	344 2 x (3 x 185 + 3G35)	
IE2-W21R 315 L4	250	1490	1602	430	250	1602	250	1602	238	1522	417	3000	3000	VSI2.0CSA_-4/0600A	480 3 x (3 x 150 + 3G25)	
IE2-W21R 315 LX4	315	1490	2019	542	277	1775	277	1775	271	1736	484	3000	3000	VSI2.0CSA_-4/0650A	520 3 x (3 x 185 + 3G35)	
IE2-W22R 355 MY4	315	1491	2019	560	315	2019	315	2019	292	1868	560	3000	3000	VSI2.0CSA_-4/0750A	600 3 x (3 x 240 + 3G50)	
IE2-W22R 355 M4	355	1493	2271	617	355	2275	355	2275	328	2100	630	3000	3000	VSI2.0CSA_-4/0860A	688 4 x (3 x 185 + 3G35)	
IE2-W22R 355 MX4	400	1494	2557	687	390	2500	390	2500	368	2358	692	3000	3000	VSI2.0CSA_-4/0860A	688 4 x (3 x 185 + 3G35)	
IE2-W22R 355 L4	500	1493	3198	900	430	2756	400	2555	390	2500	775	3000	3000	VSI2.0CSA_-4/1000A	800 4 x (3 x 240 + 3G50)	
<b>IE3</b>																
IE3-W42R 400 M4	560	1493	3582	1006	A	A	A	A	A	A	A	A	A	VSI2.0CSA_-4/1250A	1000 5 x (3 x 240 + 3G50)	
IE3-W42R 400 MX4	630	1493	4030	1119	A	A	A	A	A	A	A	A	A	VSI2.0CSA_-4/1350A	1080 6 x (3 x 185 + 3G35)	
IE3-W42R 400 L4	710	1493	4542	1261	A	A	A	A	A	A	A	A	A	VSI2.0CSA_-4/1500A	1200 6 x (3 x 240 + 3G50)	

Insulation to Sp2945

depending on requirements  
 ... 1-: Standard Dynamic (SD) or  
 ... 2-: High Dynamic (HD)

A = by request

Motor sizes > 400 by request

All motors can be supplied with optional forced ventilation at additional cost.

The "R" (rib-cooled with self-ventilation) in the type designation is to be replaced with "F" (forced ventilation).

## Technical data/selection tables

with self-ventilated 6-pole energy-saving motors for normal operation (overload 120 %, 1 minute every 10 minutes)

IE2 motors (for 50 Hz mains operation) for the output range from 0.18 kW to 315 kW

IE3 motors (for 50 Hz mains operation) for the output range from 355 to 500 kW (size 400)

Mains voltage: 400 V

Type designation	Mains operation 50 Hz				Inverter-fed operation 50 Hz			Maximum speed for P = constant	Inverter	Current	Recommended cross-sections for motor connection cable
	Rated motor output	Rated motor speed	Rated motor torque	Rated motor current	Motor output	Motor torque	Motor current				
$\hat{U}_{LL} \leq 1350$ V	P/kW	n/rpm	M/Nm	A (400 V)	P/kW	M/Nm	A (400 V)	rpm		A	mm <sup>2</sup>
IE2-W21R 71 K6	0.18	930	1.85	0.57	0.18	1.84	0.54	2000	A		
IE2-W21R 71 G6	0.25	935	2.55	0.75	0.25	2.54	0.75	2000	A		
IE2-W21R 80 K6	0.37	950	3.72	1.03	0.37	3.74	1.01	2000	A		
IE2-W21R 80 G6	0.55	950	5.53	1.5	0.55	5.56	1.49	2000	A		
IE2-W21R 90 S6	0.75	955	7.5	1.95	0.75	7.5	1.95	2000	VSI2.0WSA1-4/0003A	2.5	3 x 1.5 + 3G0.25
IE2-W21R 90 L6	1.1	955	11	2.75	1.1	11	2.75	2000	VSI2.0WSA1-4/0004A	4.0	3 x 1.5 + 3G0.25
IE2-W21R 100 LX6	1.5	955	15	3.45	1.5	15	3.45	2000	VSI2.0WSA1-4/0004A	4.0	3 x 1.5 + 3G0.25
IE2-W21R 112 MV6	2.2	955	22	5.15	2.2	22	5.15	2000	VSI2.0WSA1-4/0006A	6.0	3 x 1.5 + 3G0.25
IE2-WE1R 112 MZ6	3	955	30	7.1	3	30	6.85	2000	VSI2.0WSA1-4/0008A	7.5	3 x 1.5 + 3G0.25
IE2-W21R 132 S6	3	963	29.8	6.4	3	29.8	6.4	2000	VSI2.0WSA1-4/0008A	7.5	3 x 1.5 + 3G0.25
IE2-W21R 132 M6	4	965	39.6	8.5	4	39.6	8.5	2000	VSI2.0WSA1-4/0010A	9.5	3 x 1.5 + 3G0.25
IE2-WE2R 132 M6	4	955	40	8.3	4	40	8.3	1800	VSI2.0WSA1-4/0010A	9.5	3 x 1.5 + 3G0.25
IE2-W21R 132 MX6	5.5	970	54	12	5.5	54	12	2000	VSI2.0WSA1-4/0013A	13	3 x 2.5 + 3G0.5
IE2-W21R 160 M6	7.5	975	73	15.5	7.5	73	15.5	2000	VSI2.0WSA1-4/0018A	18	3 x 4 + 3G0.75
IE2-W21R 160 L6	11	970	108	21	11	108	21	2000	VSI2.0WSA1-4/0026A	26	3 x 6 + 3G1
IE2-W21R 180 L6	15	975	147	28.5	15	147	28.5	2000	VSI2.0WSA1-4/0031A	31	3 x 10 + 3G1.5
IE2-W21R 200 L6	18.5	980	180	35	18.5	180	35	2000	VSI2.0WSA1-4/0037A	37	3 x 10 + 3G1.5
IE2-W21R 200 LX6	22	980	214	40.5	22	214	40.5	2000	VSI2.0WSA1-4/0046A	46	3 x 16 + 3G2.5
IE2-W21R 225 M6	30	985	291	54.5	30	291	54.5	2000	VSI2.0WSA1-4/0061A	61	3 x 25 + 3G4
IE2-W21R 250 M6	37	985	359	68	37	359	68	1800	VSI2.0WSA1-4/0074A	74	3 x 35 + 3G6
IE2-W21R 280 S6	45	983	437	80.5	45	437	80.5	1800	VSI2.0WSA1-4/0090A	90	3 x 50 + 3G10
IE2-W21R 280 M6	55	990	531	100	55	531	100	1900	VSI2.0WSA1-4/0109A	109	3 x 70 + 3G10
IE2-W21R 315 S6	75	990	723	133	75	723	133	1900	VSI2.0WSA1-4/0146A	146	3 x 95 + 3G16
IE2-W21R 315 M6	90	990	868	157	90	868	157	1900	VSI2.0WSA1-4/0175A	175	3 x 120 + 3G16
IE2-W21R 315 MX6	110	990	1061	194	110	1061	194	1700	VSI2.0WSA1-4/0210A	210	3 x 185 + 3G35
IE2-W21R 315 MY6	132	990	1273	231	132	1273	231	1600	VSI2.0WSA1-4/0250A	250	3 x 240 + 3G50
IE2-W21R 315 L6	160	990	1543	277	160	1543	277	1800	VSI2.0CSA1-4/0300A	300	2 x (3 x 95 + 3G16)
IE2-W21R 315 LX6	200	990	1929	353	185	1784	323	1800	VSI2.0CSA1-4/0375A	375	2 x (3 x 150 + 3G25)
IE2-W21R 355 MY6	200	990	1929	362	200	1929	400	1600	VSI2.0CSA1-4/0430A	430	2 x (3 x 185 + 3G35)
IE2-W22R 355 M6	250	994	2402	452	250	2402	464	1600	VSI2.0CSA1-4/0500A	500	2 x (3 x 240 + 3G35)
IE2-W22R 355 MX6	315	995	3023	555	300	2879	541	1600	VSI2.0CSA1-4/0600A	600	3 x (3 x 150 + 3G25)
<b>IE3</b>											
IE3-W42R 400 MY6	355	995	3407	632	A	A	A	A	VSI2.0CSA1-4/0650A	650	3 x (3 x 185 + 3G35)
IE3-W42R 400 M6	400	993	3847	696	A	A	A	A	VSI2.0CSA1-4/0750A	750	3 x (3 x 240 + 3G50)
IE3-W42R 400 MX6	450	993	4327	821	A	A	A	A	VSI2.0CSA1-4/0860A	860	4 x (3 x 185 + 3G35)
IE3-W42R 400 L6	500	993	4808	911	A	A	A	A	VSI2.0CSA1-4/0860A	860	4 x (3 x 185 + 3G35)

Insulation to Sp2945

... 1--: Standard Dynamic (SD)

A = by request

Motor sizes > 400 by request

All motors can be supplied with optional forced ventilation at additional cost.

The "R" (rib-cooled with self-ventilation) in the type designation is to be replaced with "F" (forced ventilation).

## Technical data/selection tables

with self-ventilated 6-pole energy-saving motors for heavy duty (overload 150 %, 1 minute every 10 minutes)

IE2 motors (for 50 Hz mains operation) for the output range from 0.18 kW to 315 kW

IE3 motors (for 50 Hz mains operation) for the output range from 355 to 500 kW (size 400)

Mains voltage: 400 V

Type designation	Mains operation 50 Hz				Inverter-fed operation							Mechanical limit speed	Maximum speed for P = constant	Inverter	Current	Recommended cross-sections for motor connection cable		
	Control range	Speed range	Rated motor output	Rated motor speed	Rated motor torque	Rated motor current	Motor output	Motor torque	Motor output	Motor torque	Motor output						Motor torque	Motor current by 400 V
U <sub>LL</sub> ≤ 1350 V	P/kW	n/rpm	M/Nm	A	P/kW	M/Nm	P/kW	M/Nm	P/kW	M/Nm	A	rpm	rpm	A	mm <sup>2</sup>			
IE2-W21R 71 K6	0.18	930	1.85	0.57	0.18	1.84	0.18	1.84	0.16	1.66	0.54	11000	2000	A				
IE2-W21R 71 G6	0.25	935	2.55	0.75	0.25	2.54	0.25	2.54	0.23	2.29	0.75	11000	2000	A				
IE2-W21R 80 K6	0.37	950	3.72	1.03	0.37	3.74	0.37	3.74	0.33	3.37	1.01	10000	2000	A				
IE2-W21R 80 G6	0.55	950	5.53	1.5	0.55	5.56	0.55	5.56	0.5	5	1.49	10000	2000	A				
IE2-W21R 90 S6	0.75	955	7.5	1.95	0.75	7.5	0.75	7.5	0.68	6.75	1.95	9000	2000	VSI2.0WSA_-4/0003A	2	3 x 1.5 + 3G0.25		
IE2-W21R 90 L6	1.1	955	11	2.75	1.1	11	1.1	11	1	9.9	2.75	9000	2000	VSI2.0WSA_-4/0004A	3.2	3 x 1.5 + 3G0.25		
IE2-W21R 100 LX6	1.5	955	15	3.45	1.5	15	1.5	15	1.4	13.5	3.45	6000	2000	VSI2.0WSA_-4/0006A	4.8	3 x 1.5 + 3G0.25		
IE2-W21R 112 MV6	2.2	955	22	5.15	2.2	22	2.2	22	2	19.8	5.15	6000	2000	VSI2.0WSA_-4/0008A	6	3 x 1.5 + 3G0.25		
IE2-WE1R 112 MZ6	3	955	30	7.1	3	30	3	30	2.7	27	6.85	6000	2000	VSI2.0WSA_-4/0010A	7.6	3 x 1.5 + 3G0.25		
IE2-W21R 132 S6	3	963	29.8	6.4	3	30	3	30	2.9	29	6.4	2400	2000	VSI2.0WSA_-4/0010A	7.6	3 x 1.5 + 3G0.25		
IE2-W21R 132 M6	4	965	39.6	8.5	4	40	4	40	3.8	38	8.5	2400	1800	VSI2.0WSA_-4/0013A	10.4	3 x 2.5 + 3G0.5		
IE2-WE2R 132 M6	4	955	40	8.3	4	40	4	40	3.5	35	3.8	38	8.3	2400	2000	VSI2.0WSA_-4/0013A	10.4	3 x 2.5 + 3G0.5
IE2-W21R 132 MX6	5.5	970	54	12	5.5	54	5.5	54	5.2	51	12	2400	2000	VSI2.0WSA_-4/0018A	14.4	3 x 4 + 3G0.75		
IE2-W21R 160 M6	7.5	975	73	15.5	7.5	73	7.5	73	7.1	70	15.5	2400	2000	VSI2.0WSA_-4/0026A	21	3 x 6 + 3G1		
IE2-W21R 160 L6	11	970	108	21	11	108	11	108	10.5	103	21	2000	2000	VSI2.0WSA_-4/0026A	21	3 x 6 + 3G1		
IE2-W21R 180 L6	15	975	147	28.5	15	147	15	147	14.3	140	28.5	2000	2000	VSI2.0WSA_-4/0037A	29.6	3 x 10 + 3G1.5		
IE2-W21R 200 L6	18.5	980	180	35	18.5	180	18.5	180	17.6	172	35	2000	2000	VSI2.0WSA_-4/0046A	37	3 x 16 + 3G2.6		
IE2-W21R 200 LX6	22	980	214	40.5	22	214	22	214	20.9	204	40.5	2000	2000	VSI2.0WSA_-4/0061A	49	3 x 25 + 3G4		
IE2-W21R 225 M6	30	985	291	54.5	30	291	30	291	28.5	276	54.5	2000	2000	VSI2.0WSA_-4/0074A	59	3 x 35 + 3G6		
IE2-W21R 250 M6	37	985	359	68	37	359	37	359	35.2	341	68	2000	1800	VSI2.0WSA_-4/0090A	72	3 x 50 + 3G10		
IE2-W21R 280 S6	45	983	437	80.5	45	437	45	437	42.8	416	80.5	2000	1800	VSI2.0WSA_-4/0109A	87	3 x 70 + 3G10		
IE2-W21R 280 M6	55	990	531	100	55	531	55	531	52.3	505	100	2000	1900	VSI2.0WSA_-4/0146A	117	3 x 95 + 3G16		
IE2-W21R 315 S6	75	990	723	133	75	723	75	723	71.3	688	133	2000	1900	VSI2.0WSA_-4/0175A	140	3 x 120 + 3G16		
IE2-W21R 315 M6	90	990	868	157	90	868	90	868	85.5	825	157	2000	1900	VSI2.0WSA_-4/0210A	168	3 x 185 + 3G35		
IE2-W21R 315 MX6	110	990	1061	194	110	1061	107	1032	105	1008	194	2000	1700	VSI2.0WSA_-4/0250A	200	3 x 240 + 3G50		
IE2-W21R 315 MY6	132	990	1273	231	132	1273	132	1273	125	1210	231	2000	1600	VSI2.0CSA_-4/0300A	240	2 x (3 x 95 + 3G16)		
IE2-W21R 315 L6	160	990	1543	277	160	1543	160	1543	152	1466	277	2000	1800	VSI2.0CSA_-4/0375A	300	2 x (3 x 150 + 3G25)		
IE2-W21R 315 LX6	200	990	1929	353	185	1785	185	1785	176	1696	323	2000	1800	VSI2.0CSA_-4/0430A	344	2 x (3 x 185 + 3G35)		
IE2-W21R 355 MY6	200	990	1929	362	200	0	200	1929	190	1833	400	2000	1600	VSI2.0CSA_-4/0500A	400	2 x (3 x 240 + 3G35)		
IE2-W22R 355 M6	250	994	2402	452	250	2402	250	2402	238	2282	464	2000	1600	VSI2.0CSA_-4/0600A	480	3 x (3 x 150 + 3G25)		
IE2-W22R 355 MX6	315	995	3023	555	300	2879	300	2879	285	2735	541	2000	1600	VSI2.0CSA_-4/0750A	600	3 x (3 x 240 + 3G50)		
<b>IE3</b>																		
IE3-W42R 400 MY6	355	995	3407	632	A	A	A	A	A	A	A	A	A	VSI2.0CSA_-4/0860A	688	4 x (3 x 185 + 3G35)		
IE3-W42R 400 M6	400	993	3847	696	A	A	A	A	A	A	A	A	A	VSI2.0CSA_-4/0860A	688	4 x (3 x 185 + 3G35)		
IE3-W42R 400 MX6	450	993	4327	821	A	A	A	A	A	A	A	A	A	VSI2.0CSA_-4/1000A	800	4 x (3 x 240 + 3G50)		
IE3-W42R 400 L6	500	993	4808	911	A	A	A	A	A	A	A	A	A	VSI2.0CSA_-4/1150A	920	5 x (3 x 185 + 3G35)		

Insulation to Sp2945

depending on requirements  
 ... 1-: Standard Dynamic (SD) or  
 ... 2-: High Dynamic (HD)

A = by request

Motor sizes > 400 by request

All motors can be supplied with optional forced ventilation at additional cost.

The "R" (rib-cooled with self-ventilation) in the type designation is to be replaced with "F" (forced ventilation).

## Technical data/selection tables

with self-ventilated 2-pole energy-saving motors, series IE2-WU.R with reinforced insulation for normal operation (overload 120 %, 1 minute every 10 minutes)

IE2 motors (for 50 Hz mains operation) for the output range from 0.09 kW to 500 kW

IE3 motors (for 50 Hz mains operation) for the output range from 560 to 1000 kW (size 400 and 450)

Mains voltage: 500 V

Type designation	Mains operation 50 Hz				Inverter-fed operation 50 Hz			Maximum speed for P = constant	Inverter	Current	Recommended cross-sections for motor connection cable
	Rated motor output	Rated motor speed	Rated motor torque	Rated motor current	Motor output	Motor torque	Motor current				
$\hat{U}_{LL} \leq 1800$ V	P/kW	n/rpm	M/Nm	A (500 V)	P/kW	M/Nm	A (500 V)	rpm	Type	A	mm <sup>2</sup>
IE2-WU1R 56 K2	0.09	2825	0.3	0.18	0.09	0.3	0.18	6000	A		
IE2-WU1R 56 G2	0.12	2810	0.41	0.25	0.12	0.41	0.25	6000	A		
IE2-WU1R 63 K2	0.18	2840	0.61	0.35	0.18	0.61	0.35	6000	A		
IE2-WU1R 63 G2	0.25	2860	0.84	0.44	0.25	0.83	0.44	6000	A		
IE2-WU1R 71 K2	0.37	2860	1.24	0.62	0.37	1.24	0.62	6000	A		
IE2-WU1R 71 G2	0.55	2870	1.83	0.91	0.55	1.83	0.91	6000	A		
IE2-WU1R 80 K2	0.75	2880	2.5	1.2	0.75	2.5	1.2	6000	A		
IE2-WU1R 80 G2	1.1	2885	3.6	1.7	1.1	3.6	1.7	6000	VSI2.0WSA1-5/0003A	2.5	3 x 1.5 + 3G0.25
IE2-WU1R 90 S2	1.5	2910	4.9	2.3	1.5	4.9	2.3	6000	VSI2.0WSA1-5/0003A	2.5	3 x 1.5 + 3G0.25
IE2-WU1R 90 L2	2.2	2880	7.3	3.4	2.2	7.3	3.4	6000	VSI2.0WSA1-5/0004A	4	3 x 1.5 + 3G0.25
IE2-WU1R 100 L2	3	2930	9.8	5.2	3	9.8	5.3	6000	VSI2.0WSA1-5/0006A	6	3 x 1.5 + 3G0.25
IE2-WU1R 112 MX2	4	2920	13.1	6.3	4	13.1	6.4	6000	VSI2.0WSA1-5/0008A	7.5	3 x 1.5 + 3G0.25
IE2-WU1R 112 MV2	5.5	2900	18.1	8.2	5.5	18.1	8.3	6000	VSI2.0WSA1-5/0010A	9.5	3 x 1.5 + 3G0.25
IE2-WU1R 132 S2T	5.5	2900	18.1	8.2	5.5	18.1	8.3	6000	VSI2.0WSA1-5/0010A	9.5	3 x 1.5 + 3G0.25
IE2-WU1R 132 S2	5.5	2915	18	8.4	5.5	18	8.4	6000	VSI2.0WSA1-5/0010A	9.5	3 x 1.5 + 3G0.25
IE2-WU1R 132 SX2	7.5	2920	24.5	11	7.5	24.5	11	6000	VSI2.0WSA1-5/0013A	13	3 x 2.5 + 3G0.5
IE2-WU1R 160 M2	11	2940	35.7	16	11	35.6	16	6000	VSI2.0WSA1-5/0018A	18	3 x 4 + 3G0.75
IE2-WU1R 160 MX2	15	2935	48.8	21	15	48.7	21	6000	VSI2.0WSA1-5/0026A	26	3 x 6 + 3G1
IE2-WU1R 160 L2	18.5	2935	60.2	26	18.5	60.2	26	6000	VSI2.0WSA1-5/0031A	31	3 x 10 + 3G1.5
IE2-WU1R 180 M2	22	2940	71	31	22	72	31	5400	VSI2.0WSA1-5/0037A	37	3 x 10 + 3G1.5
IE2-WU1R 200 L2	30	2950	97	42	30	97	41	6000	VSI2.0WSA1-5/0046A	46	3 x 16 + 3G2.5
IE2-WU2R 200 LX2	37	2955	120	51	37	120	51	6000	VSI2.0WSA1-5/0061A	61	3 x 25 + 3G4
IE2-WU1R 225 M2	45	2950	146	64	45	146	64	5000	VSI2.0WSA1-6/0074A	74	3 x 35 + 3G6
IE2-WU1R 250 M2	55	2956	178	76	55	178	76	4500	VSI2.0WSA1-6/0090A	90	3 x 50 + 3G10
IE2-WU1R 280 S2	75	2970	241	102	75	241	102	4300	VSI2.0WSA1-6/0109A	109	3 x 70 + 3G10
IE2-WU1R 280 M2	90	2970	289	121	90	289	121	4300	VSI2.0WSA1-6/0146A	146	3 x 95 + 3G16
IE2-WU1R 315 S2	110	2975	353	151	110	353	151	3800	VSI2.0WSA1-6/0175A	175	3 x 120 + 3G16
IE2-WU1R 315 M2	132	2975	424	180	132	424	180	3800	VSI2.0WSA1-6/0200A	200	3 x 150 + 3G25
IE2-WU1R 315 MX2	160	2973	514	219	160	514	219	3600	VSI2.0CSA1-6/0250A	250	2 x (3 x 70 + 3G10)
IE2-WU1R 315 MY2	200	2983	640	275	200	640	275	3600	VSI2.0CSA1-6/0300A	300	2 x (3 x 95 + 3G16)
IE2-WU1R 315 L2	250	2984	800	329	220	704	285	3600	VSI2.0CSA1-6/0300A	300	2 x (3 x 95 + 3G16)
IE2-WU1R 315 LX2	315	2985	1008	414	270	864	350	3600	VSI2.0CSA1-6/0375A	375	2 x (3 x 150 + 3G25)
IE2-WU2R 355 MY2	315	2988	1008	427	315	1008	427	3600	VSI2.0CSA1-6/0430A	430	3 x (3 x 95 + 3G16)
IE2-WU2R 355 M2	355	2985	1136	466	330	1056	434	3600	VSI2.0CSA1-6/0500A	500	3 x (3 x 120 + 3G16)
IE2-WU2R 355 MX2	400	2990	1278	531	355	1134	470	3600	VSI2.0CSA1-6/0500A	500	3 x (3 x 120 + 3G16)
IE2-WU2R 355 LY2	450	2985	1440	591	425	1360	560	3600	VSI2.0CSA1-6/0595A	600	3 x (3 x 150 + 3G25)
IE2-WU2R 355 L2	500	2990	1597	657	425	1357	560	3600	VSI2.0CSA1-6/0595A	600	3 x (3 x 150 + 3G25)
<b>IE3</b>											
IE3-WU2R 400 M2	560	2988	1790	772	A	A	A	A	VSI2.0CSA1-6/0800A	800	4 x (3 x 150 + 3G25)
IE3-WU2R 400 MX2	630	2988	2014	856	A	A	A	A	VSI2.0CSA1-6/0800A	800	4 x (3 x 150 + 3G25)
IE3-WU2R 400 L2	710	2988	2269	956	A	A	A	A	VSI2.0CSA1-6/0995A	1000	5 x (3 x 150 + 3G25)
IE3-WU2R 450 M2	800	2988	2557	1096	A	A	A	A	VSI2.0CSA1-6/1200A	1200	6 x (3 x 150 + 3G25)
IE3-WU2R 450 MX2	900	2988	2876	1232	A	A	A	A	VSI2.0CSA1-6/1200A	1200	6 x (3 x 150 + 3G25)
IE3-WU2R 450 L2	1000	2990	3194	1340	A	A	A	A	VSI2.0CSA1-6/1400A	1400	7 x (3 x 150 + 3G25)

Withstand voltage  $\hat{U}_{LL} \leq 1560$  V

... 1-: Standard Dynamic (SD)

A = by request

Motor sizes > 450 by request

All motors can be supplied with optional forced ventilation at additional cost.

The "R" (rib-cooled with self-ventilation) in the type designation is to be replaced with "F" (forced ventilation).

## Technical data/selection tables

with self-ventilated 2-pole energy-saving motors, series IE2-WU.R with reinforced insulation for heavy duty (overload 150 %, 1 minute every 10 minutes)

IE2 motors (for 50 Hz mains operation) for the output range from 0.09 kW to 500 kW

IE3 motors (for 50 Hz mains operation) for the output range from 560 to 1000 kW (size 400 and 450)

Mains voltage: 500 V

Type designation	Mains operation 50 Hz				Inverter-fed operation							Mechanical limit speed	Maximum speed for P = constant	Inverter	Current	Recommended cross-sections for motor connection cable
	P/kW	n/ rpm	M/ Nm	A (500 V)	1:2.5		1:5		1:10							
Speed range					1200 – 3000 rpm		600 – 3000 rpm		300 – 3000 rpm							
Ü <sub>LL</sub> ≤ 1800 V	Rated motor output	Rated motor speed	Rated motor torque	Rated motor current	Motor output	Motor torque	Motor output	Motor torque	Motor output	Motor torque	Motor current by 500 V	Type				
	P/kW	n/ rpm	M/ Nm	A (500 V)	P/ kW	M/ Nm	P/ kW	M/ Nm	P/ kW	M/ Nm	A	rpm	rpm	A	mm <sup>2</sup>	
IE2-WU1R 56 K2	0.09	2825	0.3	0.18	0.09	0.3	0.09	0.3	0.07	0.24	0.18	15000	6000	A		
IE2-WU1R 56 G2	0.12	2810	0.41	0.25	0.12	0.41	0.12	0.41	0.1	0.33	0.25	15000	6000	A		
IE2-WU1R 63 K2	0.18	2840	0.61	0.35	0.18	0.61	0.18	0.61	0.14	0.5	0.35	15000	6000	A		
IE2-WU1R 63 G2	0.25	2860	0.84	0.44	0.25	0.83	0.25	0.83	0.2	0.66	0.44	15000	6000	A		
IE2-WU1R 71 K2	0.37	2860	1.24	0.62	0.37	1.24	0.37	1.24	0.3	1	0.62	14000	6000	A		
IE2-WU1R 71 G2	0.55	2870	1.83	0.91	0.55	1.83	0.55	1.83	0.44	1.46	0.91	14000	6000	A		
IE2-WU1R 80 K2	0.75	2880	2.5	1.2	0.75	2.5	0.75	2.5	0.6	2.0	1.2	13000	6000	VSI2.0WSA_-5/0003A	2	3 x 1.5 + 3G0.25
IE2-WU1R 80 G2	1.1	2885	3.6	1.7	1.1	3.6	1.1	3.6	0.9	3.0	1.7	13000	6000	VSI2.0WSA_-5/0003A	2	3 x 1.5 + 3G0.25
IE2-WU1R 90 S2	1.5	2910	4.9	2.3	1.5	4.9	1.5	4.9	1.2	3.9	2.3	11000	6000	VSI2.0WSA_-5/0004A	3.2	3 x 1.5 + 3G0.25
IE2-WU1R 90 L2	2.2	2880	7.3	3.4	2.2	7.3	2.2	7.3	1.8	6.0	3.4	11000	6000	VSI2.0WSA_-5/0006A	4.8	3 x 1.5 + 3G0.25
IE2-WU1R 100 L2	3	2930	9.8	5.2	3	9.8	3	9.8	2.4	7.9	5.3	10000	6000	VSI2.0WSA_-5/0008A	6	3 x 1.5 + 3G0.25
IE2-WU1R 112 MX2	4	2920	13.1	6.3	4	13.1	4	13.1	3.2	10.5	6.4	7000	6000	VSI2.0WSA_-5/0010A	7.6	3 x 1.5 + 3G0.25
IE2-WU1R 112 MV2	5.5	2900	18.1	8.2	5.5	18.1	5.5	18.1	4.4	14.5	8.3	7000	6000	VSI2.0WSA_-5/0013A	10.4	3 x 2.5 + 3G0.5
IE2-WU1R 132 S2T	5.5	2900	18.1	8.2	5.5	18.1	5.5	18.1	4.4	14.5	8.3	7000	6000	VSI2.0WSA_-5/0013A	10.4	3 x 2.5 + 3G0.5
IE2-WU1R 132 S2	5.5	2915	18	8.4	5.5	18	5.5	18	5.2	17	8.4	7000	6000	VSI2.0WSA_-5/0013A	10.4	3 x 2.5 + 3G0.5
IE2-WU1R 132 SX2	7.5	2920	24.5	11	7.5	24	7.5	24	7.1	23	11	7000	6000	VSI2.0WSA_-5/0018A	14.4	3 x 4 + 3G0.75
IE2-WU1R 160 M2	11	2940	35.7	16	11	36	11	36	10.5	34	16	7000	6000	VSI2.0WSA_-5/0026A	21	3 x 6 + 3G1
IE2-WU1R 160 MX2	15	2935	48.8	21	15	49	15	49	14.3	46	21	6000	6000	VSI2.0WSA_-5/0031A	25	3 x 10 + 3G1.5
IE2-WU1R 160 L2	18.5	2935	60.2	26	18.5	60	18.5	60	17.6	57	26	6000	6000	VSI2.0WSA_-5/0037A	29.6	3 x 10 + 3G1.5
IE2-WU1R 180 M2	22	2940	71	31	22	72	22	72	21	68	31	6000	5400	VSI2.0WSA_-5/0046A	37	3 x 16 + 3G2.5
IE2-WU1R 200 L2	30	2950	97	42	30	97	30	97	28.5	92	41	6000	6000	VSI2.0WSA_-5/0061A	49	3 x 25 + 3G4
IE2-WU2R 200 LX2	37	2955	120	51	37	120	37	120	35	114	51	6000	6000	VSI2.0WSA_-5/0074A	59	3 x 35 + 3G6
IE2-WU1R 225 M2	45	2950	146	64	45	146	45	146	43	139	64	5000	5000	VSI2.0WSA_-6/0090A	72	3 x 50 + 3G10
IE2-WU1R 250 M2	55	2956	178	76	55	178	55	178	52	169	76	4500	4500	VSI2.0WSA_-6/0109A	87	3 x 70 + 3G10
IE2-WU1R 280 S2	75	2970	241	102	75	241	75	241	71	229	102	4300	4300	VSI2.0WSA_-6/0146A	117	3 x 95 + 3G16
IE2-WU1R 280 M2	90	2970	289	121	90	289	90	289	86	275	121	4300	4300	VSI2.0WSA_-6/0175A	140	3 x 120 + 3G16
IE2-WU1R 315 S2	110	2975	353	151	110	353	110	353	105	335	151	3800	3800	VSI2.0WSA_-6/0200A	160	3 x 150 + 3G25
IE2-WU1R 315 M2	132	2975	424	180	132	424	132	424	125	403	180	3800	3800	VSI2.0CSA_-6/0250A	200	2 x (3 x 70 + 3G10)
IE2-WU1R 315 MX2	160	2973	514	219	160	514	160	514	152	488	219	3600	3600	VSI2.0CSA_-6/0300A	240	2 x (3 x 95 + 3G16)
IE2-WU1R 315 MY2	200	2983	640	275	192	615	192	615	190	608	275	3600	3600	VSI2.0CSA_-6/0375A	300	2 x (3 x 150 + 3G25)
IE2-WU1R 315 L2	250	2984	800	329	220	704	220	704	209	669	285	3600	3600	VSI2.0CSA_-6/0400A	320	2 x (3 x 150 + 3G25)
IE2-WU1R 315 LX2	315	2985	1008	414	270	864	270	864	257	821	350	3600	3600	VSI2.0CSA_-6/0500A	400	3 x (3 x 120 + 3G16)
IE2-WU2R 355 MY2	315	2988	1008	427	315	1007	315	1007	299	957	427	3600	3600	VSI2.0CSA_-6/0595A	480	3 x (3 x 150 + 3G25)
IE2-WU2R 355 M2	355	2985	1136	466	330	1056	330	1056	314	1003	434	3600	3600	VSI2.0CSA_-6/0595A	480	3 x (3 x 150 + 3G25)
IE2-WU2R 355 MX2	400	2990	1278	531	355	1134	355	1134	337	1077	470	3600	3600	VSI2.0CSA_-6/0650A	520	4 x (3 x 120 + 3G16)
IE2-WU2R 355 LY2	450	2985	1440	591	370	1184	370	1184	370	1184	560	3600	3600	VSI2.0CSA_-6/0720A	576	4 x (3 x 150 + 3G25)
IE2-WU2R 355 L2	500	2990	1597	657	370	1182	370	1182	370	1182	560	3600	3600	VSI2.0CSA_-6/0720A	576	4 x (3 x 150 + 3G25)
<b>IE3</b>																
IE3-WU2R 400 M2	560	2988	1790	772	A	A	A	A	A	A	A	A	A	VSI2.0CSA_-6/0995A	800	5 x (3 x 150 + 3G25)
IE3-WU2R 400 MX2	630	2988	2014	856	A	A	A	A	A	A	A	A	A	VSI2.0CSA_-6/1200A	960	6 x (3 x 150 + 3G25)
IE3-WU2R 400 L2	710	2988	2269	956	A	A	A	A	A	A	A	A	A	VSI2.0CSA_-6/1200A	960	6 x (3 x 150 + 3G25)
IE3-WU2R 450 M2	800	2988	2557	1096	A	A	A	A	A	A	A	A	A	VSI2.0CSA_-6/1400A	1120	7 x (3 x 150 + 3G25)
IE3-WU2R 450 MX2	900	2988	2876	1232	A	A	A	A	A	A	A	A	A	VSI2.0CSA_-6/1600A	1280	A
IE3-WU2R 450 L2	1000	2990	3194	1340	A	A	A	A	A	A	A	A	A	VSI2.0CSA_-6/1800A	1440	A

Withstand voltage Ü<sub>LL</sub> ≤ 1560 V

A = by request

All motors can be supplied with optional forced ventilation at additional cost.

Motor sizes > 450 by request

The "R" (rib-cooled with self-ventilation) in the type designation is to be replaced with "F" (forced ventilation).

depending on requirements

... 1-: Standard Dynamic (SD) or  
... 2-: High Dynamic (HD)

## Technical data/selection tables

with self-ventilated 4-pole energy-saving motors, series IE2-WU.R with reinforced insulation for normal operation (overload 120 %, 1 minute every 10 minutes)

IE2 motors (for 50 Hz mains operation) for the output range from 0.06 kW to 500 kW

IE3 motors (for 50 Hz mains operation) for the output range from 560 to 1000 kW (size 400 and 450)

Mains voltage: 500 V

Type designation	Mains operation 50 Hz				Inverter-fed operation 50 Hz			Maximum speed for P = constant	Inverter	Current	Recommended cross-sections for motor connection cable
	Rated motor output	Rated motor speed	Rated motor torque	Rated motor current	Motor output	Motor torque	Motor current				
$\hat{U}_{LL} \leq 1800 \text{ V}$	P/kW	n/rpm	M/Nm	A	P/kW	M/Nm	A (500 V)	rpm	Type	A	mm <sup>2</sup>
IE2-WU1R 56 K4	0.06	1400	0.41	0.16	0.06	0.41	0	3000	A		
IE2-WU1R 56 G4	0.09	1370	0.63	0.22	0.09	0.63	0	3000	A		
IE2-WU1R 63 K4	0.12	1400	0.82	0.28	0.12	0.82	0.28	3000	A		
IE2-WU1R 63 G4	0.18	1425	1.21	0.46	0.18	1.21	0	3000	A		
IE2-WU1R 71 K4	0.25	1430	1.7	0.53	0.25	1.7	0.53	3000	A		
IE2-WU1R 71 G4	0.37	1430	2.5	0.78	0.37	2.5	0.78	3000	A		
IE2-WU1R 80 K4	0.55	1430	3.7	1	0.55	3.7	1	3000	A		
IE2-WU1R 80 G4	0.75	1430	5.0	1.3	0.75	5.0	1.3	3000	A		
IE2-WU1R 90 S4	1.1	1435	7.3	2	1.1	7.3	2	3000	VSI2.0WSA1-5/0003A	2.5	3 x 1.5 + 3G0.25
IE2-WU1R 90 L4	1.5	1445	9.9	2.7	1.5	9.9	2.7	3000	VSI2.0WSA1-5/0004A	4	3 x 1.5 + 3G0.25
IE2-WU1R 100 L4	2.2	1455	14.4	3.8	2.2	14.4	3.9	3000	VSI2.0WSA1-5/0004A	4	3 x 1.5 + 3G0.25
IE2-WU1R 100 LX4	3	1455	19.7	5.2	3	19.7	5.2	3000	VSI2.0WSA1-5/0006A	6	3 x 1.5 + 3G0.25
IE2-WU1R 112 MZ4	4	1445	26.4	6.6	4	26.4	6.7	3000	VSI2.0WSA1-5/0008A	7.5	3 x 1.5 + 3G0.25
IE2-WU1R 112 M4	4	1460	26.2	6.2	4	26.2	6.2	3000	VSI2.0WSA1-5/0008A	7.5	3 x 1.5 + 3G0.25
IE2-WU1R 132 S4	5.5	1465	35.9	8	5.5	35.7	8	3000	VSI2.0WSA1-5/0010A	9.5	3 x 1.5 + 3G0.25
IE2-WU2R 132 S4	5.5	1450	36.2	8	5.5	36.2	8	3000	VSI2.0WSA1-5/0010A	9.5	3 x 1.5 + 3G0.25
IE2-WU1R 132 M4	7.5	1470	48.7	12	7.5	48.7	12	3000	VSI2.0WSA1-5/0013A	13	3 x 2.5 + 3G0.5
IE2-WU1R 160 M4	11	1475	71	17	11	71	17	3000	VSI2.0WSA1-5/0018A	18	3 x 4 + 3G0.75
IE2-WU2R 160 L4	15	1475	97	23	15	97	22	3000	VSI2.0WSA1-5/0026A	26	3 x 6 + 3G1
IE2-WU1R 180 M4	18.5	1475	120	28	18.5	120	27	3000	VSI2.0WSA1-5/0031A	31	3 x 10 + 3G1.5
IE2-WU1R 180 L4	22	1475	142	34	22	142	34	3000	VSI2.0WSA1-5/0037A	37	3 x 10 + 3G1.5
IE2-WU1R 200 L4	30	1480	194	48	30	194	47	3000	VSI2.0WSA1-5/0061A	61	3 x 25 + 3G4
IE2-WU1R 225 S4	37	1475	240	56	37	240	55	3000	VSI2.0WSA1-5/0061A	61	3 x 25 + 3G4
IE2-WU1R 225 M4	45	1483	290	66	45	290	66	2600	VSI2.0WSA1-5/0074A	74	3 x 35 + 3G6
IE2-WU1R 250 M4	55	1485	354	81	55	354	81	2600	VSI2.0WSA1-6/0090A	90	3 x 50 + 3G10
IE2-WU1R 280 S4	75	1485	482	110	75	482	110	2400	VSI2.0WSA1-6/0146A	146	3 x 95 + 3G16
IE2-WU1R 280 M4	90	1483	580	131	90	580	131	2600	VSI2.0WSA1-6/0146A	146	3 x 95 + 3G16
IE2-WU1R 315 S4	110	1485	707	163	110	707	163	3000	VSI2.0WSA1-6/0175A	175	3 x 120 + 3G16
IE2-WU1R 315 M4	132	1484	849	194	132	849	194	2600	VSI2.0WSA1-6/0200A	200	3 x 150 + 3G25
IE2-WU1R 315 MX4	160	1482	1031	231	160	1031	231	2500	VSI2.0CSA1-6/0250A	250	2 x (3 x 70 + 3G10)
IE2-WU1R 315 MY4	200	1490	1282	279	200	1282	274	2800	VSI2.0CSA1-6/0300A	300	2 x (3 x 95 + 3G16)
IE2-WU1R 315 L4	250	1490	1602	344	250	1608	334	3000	VSI2.0CSA1-6/0375A	375	2 x (3 x 150 + 3G25)
IE2-WU1R 315 LX4	315	1490	2019	434	285	1827	387	3000	VSI2.0CSA1-6/0430A	430	3 x (3 x 95 + 3G16)
IE2-WU2R 355 MY4	315	1491	2019	448	315	2019	448	3000	VSI2.0CSA1-6/0500A	500	3 x (3 x 120 + 3G16)
IE2-WU2R 355 M4	355	1493	2271	494	355	2271	504	3000	VSI2.0CSA1-6/0595A	600	3 x (3 x 150 + 3G25)
IE2-WU2R 355 MX4	400	1494	2557	550	390	2493	554	3000	VSI2.0CSA1-6/0595A	600	3 x (3 x 150 + 3G25)
IE2-WU2R 355 LY4	450	1496	2873	633	430	2745	626	3000	VSI2.0CSA1-6/0650A	650	4 x (3 x 120 + 3G16)
IE2-WU2R 355 L4	500	1493	3198	720	430	2745	626	3000	VSI2.0CSA1-6/0650A	650	4 x (3 x 120 + 3G16)
<b>IE3</b>											
IE3-WU2R 400 M4	560	1493	3582	805	A	A	A	A	VSI2.0CSA1-6/0800A	800	4 x (3 x 150 + 3G25)
IE3-WU2R 400 MX4	630	1493	4030	895	A	A	A	A	VSI2.0CSA1-6/0995A	1000	5 x (3 x 150 + 3G25)
IE3-WU2R 400 L4	710	1493	4542	1009	A	A	A	A	VSI2.0CSA1-6/0995A	1000	5 x (3 x 150 + 3G25)
IE3-WU2R 450 M4	800	1493	5117	1150	A	A	A	A	VSI2.0CSA1-6/1200A	1200	6 x (3 x 150 + 3G25)
IE3-WU2R 450 MX4	900	1493	5757	1264	A	A	A	A	VSI2.0CSA1-6/1200A	1200	6 x (3 x 150 + 3G25)
IE3-WU2R 450 L4	1000	1493	6397	1404	A	A	A	A	VSI2.0CSA1-6/1400A	1400	7 x (3 x 150 + 3G25)

Withstand voltage:  $\hat{U}_{LL} \leq 1560 \text{ V}$

... 1--: Standard Dynamic (SD)

A = by request

Motor sizes > 450 by request

All motors can be supplied with optional forced ventilation at additional cost.

The "R" (rib-cooled with self-ventilation) in the type designation is to be replaced with "F" (forced ventilation).

## Technical data/selection tables

with self-ventilated 4-pole energy-saving motors, series IE2-WU.R with reinforced insulation for heavy duty (overload 150 %, 1 minute every 10 minutes)

IE2 motors (for 50 Hz mains operation) for the output range from 0.06 kW to 500 kW

IE3 motors (for 50 Hz mains operation) for the output range from 560 to 1000 kW (size 400 and 450)

Mains voltage: 500 V

Type designation	Mains operation 50 Hz				Inverter-fed operation								Mechanical limit speed	Maximum speed for P = constant	Inverter	Current	Recommended cross-sections for motor connection cable		
	Control range	Speed range	1:2.5	1:5	1:10	600 – 1500 rpm	300 – 1500 rpm	150 – 1500 rpm	Rated motor output	Rated motor speed	Rated motor torque	Rated motor current						Motor output	Motor torque
$\hat{U}_{LL} \leq 1800$ V	P/kW	n/ rpm	M/ Nm	A (500 V)	P/ kW	M/ Nm	P/ kW	M/ Nm	P/ kW	M/ Nm	P/ kW	M/ Nm	A	rpm	rpm		A	mm <sup>2</sup>	
IE2-WU1R 56 K4	0.06	1400	0.41	0.16	0.06	0.41	0.06	0.41	0.05	0.33	0	12000	3000	A					
IE2-WU1R 56 G4	0.09	1370	0.63	0.22	0.09	0.63	0.09	0.63	0.07	0.5	0	12000	3000	A					
IE2-WU1R 63 K4	0.12	1400	0.82	0.28	0.12	0.82	0.12	0.82	0.09	0.65	0.28	12000	3000	A					
IE2-WU1R 63 G4	0.18	1425	1.21	0.46	0.18	1.21	0.18	1.21	0.14	0.97	0	12000	3000	A					
IE2-WU1R 71 K4	0.25	1430	1.7	0.53	0.25	1.7	0.25	1.7	0.2	1.3	0.53	11000	3000	A					
IE2-WU1R 71 G4	0.37	1430	2.5	0.78	0.37	2.5	0.37	2.5	0.3	2.0	0.78	11000	3000	A					
IE2-WU1R 80 K4	0.55	1430	3.7	1	0.55	3.7	0.55	3.7	0.44	2.9	1	11000	3000	A					
IE2-WU1R 80 G4	0.75	1430	5.0	1.3	0.75	5.0	0.75	5.0	0.6	4.0	1.32	11000	3000	A					
IE2-WU1R 90 S4	1.1	1435	7.3	2	1.1	7.3	1.1	7.3	0.9	6.0	2	9000	3000	VS12.0WSA_-5/0003A	2	3 x 1.5 + 3G0.25			
IE2-WU1R 90 L4	1.5	1445	9.9	2.7	1.5	9.9	1.5	9.9	1.2	7.9	2.7	9000	3000	VS12.0WSA_-5/0004A	3.2	3 x 1.5 + 3G0.25			
IE2-WU1R 100 L4	2.2	1455	14.4	3.8	2.2	14.4	2.2	14.4	1.8	11.8	3.9	8000	3000	VS12.0WSA_-5/0006A	4.8	3 x 1.5 + 3G0.25			
IE2-WU1R 100 LX4	3	1455	19.7	5.2	3	19.7	3	19.7	2.4	15.8	5.2	6000	3000	VS12.0WSA_-5/0008A	6	3 x 1.5 + 3G0.25			
IE2-WU1R 112 MZ4	4	1445	26.4	6.6	4	26.4	4	26.4	3.2	21.1	6.7	6000	3000	VS12.0WSA_-5/0010A	7.6	3 x 1.5 + 3G0.25			
IE2-WU1R 112 M4	4	1460	26.2	6.2	4	26.2	3.7	24	3.8	25	6.2	6000	3000	VS12.0WSA_-5/0010A	7.6	3 x 1.5 + 3G0.25			
IE2-WU1R 132 S4	5.5	1465	35.9	8	5.5	35.7	5.5	36	5.2	34	8	3600	3000	VS12.0WSA_-5/0013A	10.4	3 x 2.5 + 3G0.5			
IE2-WU2R 132 S4	5.5	1450	36.2	8	5.5	36.2	5	33	5.2	34	8	3600	3000	VS12.0WSA_-5/0013A	10.4	3 x 2.5 + 3G0.5			
IE2-WU1R 132 M4	7.5	1470	48.7	12	7.5	48.7	7.5	49	7.1	46	12	3600	3000	VS12.0WSA_-5/0018A	14.4	3 x 4 + 3G0.75			
IE2-WU1R 160 M4	11	1475	71	17	11	71	11	71	10.5	68	17	3600	3000	VS12.0WSA_-5/0026A	21	3 x 6 + 3G1			
IE2-WU2R 160 L4	15	1475	97	23	15	97	15	97	14.3	92	22	3600	3000	VS12.0WSA_-5/0031A	25	3 x 10 + 3G1.5			
IE2-WU1R 180 M4	18.5	1475	120	28	18.5	120	18.5	120	17.6	114	27	3000	3000	VS12.0WSA_-5/0037A	29.6	3 x 10 + 3G1.5			
IE2-WU1R 180 L4	22	1475	142	34	22	142	22	142	20.9	135	34	3000	3000	VS12.0WSA_-5/0046A	37	3 x 16 + 3G2.6			
IE2-WU1R 200 L4	30	1480	194	48	30	194	30	194	28.5	184	47	3000	3000	VS12.0WSA_-5/0061A	49	3 x 25 + 3G4			
IE2-WU1R 225 S4	37	1475	240	56	37	240	37	240	35.2	228	55	3000	3000	VS12.0WSA_-5/0074A	59	3 x 35 + 3G6			
IE2-WU1R 225 M4	45	1483	290	66	45	290	45	290	42.8	276	66	3000	2600	VS12.0WSA_-6/0090A	72	3 x 50 + 3G10			
IE2-WU1R 250 M4	55	1485	354	81	55	354	55	354	52.3	336	81	3000	2600	VS12.0WSA_-6/0109A	87	3 x 70 + 3G10			
IE2-WU1R 280 S4	75	1485	482	110	75	482	75	482	71.3	459	110	3000	2400	VS12.0WSA_-6/0146A	117	3 x 95 + 3G16			
IE2-WU1R 280 M4	90	1483	580	131	90	580	90	580	85.5	551	131	3000	2600	VS12.0WSA_-6/0175A	140	3 x 120 + 3G16			
IE2-WU1R 315 S4	110	1485	707	163	110	707	110	707	104.5	672	163	3000	3000	VS12.0WSA_-6/0200A	160	3 x 150 + 3G25			
IE2-WU1R 315 M4	132	1484	849	194	132	849	132	849	125.4	807	194	3000	2600	VS12.0CSA_-6/0250A	200	2 x (3 x 70 + 3G10)			
IE2-WU1R 315 MX4	160	1482	1031	231	160	1031	160	1031	152	979	231	3000	2500	VS12.0CSA_-6/0300A	240	2 x (3 x 95 + 3G16)			
IE2-WU1R 315 MY4	200	1490	1282	279	200	1282	200	1282	190	1218	274	3000	2800	VS12.0CSA_-6/0375A	300	2 x (3 x 150 + 3G25)			
IE2-WU1R 315 L4	250	1490	1602	344	250	1608	250	1602	237.5	1522	334	3000	3000	VS12.0CSA_-6/0430A	344	3 x (3 x 95 + 3G16)			
IE2-WU1R 315 LX4	315	1490	2019	434	277	1780	277	1775	270.8	1736	387	3000	3000	VS12.0CSA_-6/0500A	400	3 x (3 x 120 + 3G16)			
IE2-WU2R 355 MY4	315	1491	2019	448	315	2019	315	2019	292	1868	448	3000	3000	VS12.0CSA_-6/0595A	480	3 x (3 x 150 + 3G25)			
IE2-WU2R 355 M4	355	1493	2275	494	355	2275	355	2275	328	2100	504	3000	3000	VS12.0CSA_-6/0650A	520	4 x (3 x 120 + 3G16)			
IE2-WU2R 355 MX4	400	1494	2557	550	390	2500	390	2500	368	2358	554	3000	3000	VS12.0CSA_-6/0720A	576	4 x (3 x 150 + 3G25)			
IE2-WU2R 355 LY4	450	1496	2873	633	430	2756	400	2555	390	2500	626	3000	3000	VS12.0CSA_-6/0800A	640	4 x (3 x 150 + 3G25)			
IE2-WU2R 355 L4	500	1493	3198	720	430	2756	400	2555	390	2500	620	3000	3000	VS12.0CSA_-6/0800A	640	4 x (3 x 150 + 3G25)			

### IE3

IE3-WU2R 400 M4	560	1493	3582	805	A	A	A	A	A	A	A	A	A	VS12.0CSA_-6/0995A	800	5 x (3 x 150 + 3G25)			
IE3-WU2R 400 MX4	630	1493	4030	895	A	A	A	A	A	A	A	A	A	VS12.0CSA_-6/1200A	960	6 x (3 x 150 + 3G25)			
IE3-WU2R 400 L4	710	1493	4542	1009	A	A	A	A	A	A	A	A	A	VS12.0CSA_-6/1400A	1120	7 x (3 x 150 + 3G25)			
IE3-WU2R 450 M4	800	1493	5117	1150	A	A	A	A	A	A	A	A	A	VS12.0CSA_-6/1400A	1120	7 x (3 x 150 + 3G25)			
IE3-WU2R 450 MX4	900	1493	5757	1264	A	A	A	A	A	A	A	A	A	VS12.0CSA_-6/1600A	1280	A			
IE3-WU2R 450 L4	1000	1493	6397	1404	A	A	A	A	A	A	A	A	A	VS12.0CSA_-6/1800A	1440	A			

Withstand voltage  $\hat{U}_{LL} \leq 1560$  V

A = by request  
All motors can be supplied with optional forced ventilation at additional cost.

Motor sizes > 450 by request  
The "R" (rib-cooled with self-ventilation) in the type designation is to be replaced with "F" (forced ventilation).

depending on requirements  
... 1-: Standard Dynamic (SD) or  
... 2-: High Dynamic (HD)

## Technical data/selection tables

with self-ventilated 6-pole energy-saving motors, series IE2-WU.R with reinforced insulation for normal operation (overload 120 %, 1 minute every 10 minutes)

IE2 motors (for 50 Hz mains operation) for the output range from 0.18 kW to 355 kW

IE3 motors (for 50 Hz mains operation) for the output range from 355 to 710 kW (size 400 and 450)

Mains voltage: 500 V

Type designation	Mains operation 50 Hz				Inverter-fed operation 50 Hz			Maximum speed for P = constant	Inverter	Current	Recommended cross-sections for motor connection cable
	Rated motor output	Rated motor speed	Rated motor torque	Rated motor current	Motor output	Motor torque	Motor current				
$\hat{U}_{LL} \leq 1800 \text{ V}$	P/kW	n/rpm	M/Nm	A	P/kW	M/Nm	A (500 V)	rpm	Type	A	mm <sup>2</sup>
IE2-WU1R 71 K6	0.18	930	1.9	0.46	0.18	1.9	0.46	2000	A		
IE2-WU1R 71 G6	0.25	935	2.6	0.6	0.25	2.6	0.6	2000	A		
IE2-WU1R 80 K6	0.37	950	3.7	0.82	0.37	3.7	0.82	2000	A		
IE2-WU1R 80 G6	0.55	950	5.5	1.2	0.55	5.5	1.2	2000	A		
IE2-WU1R 90 S6	0.75	955	7.5	1.6	0.75	7.5	2	2000	VSI2.0WSA1-5/0003A	2.2	3 x 1.5 + 3G0.25
IE2-WU1R 90 L6	1.1	955	11	2.2	1.1	11	2	2000	VSI2.0WSA1-5/0003A	2.2	3 x 1.5 + 3G0.25
IE2-WU1R 100 LX6	1.5	955	15	2.8	1.5	15	3	2000	VSI2.0WSA1-5/0004A	4	3 x 1.5 + 3G0.25
IE2-WU1R 112 MV6	2.2	955	22	4.1	2.2	22	A	2000	VSI2.0WSA1-5/0006A	6	3 x 1.5 + 3G0.25
IE2-WU1R 112 MZ6	3	955	30	5.7	3	30	6	2000	VSI2.0WSA1-5/0006A	6	3 x 1.5 + 3G0.25
IE2-WU1R 132 S6	3	963	29.8	5.1	3	29.8	5	2000	VSI2.0WSA1-5/0006A	6	3 x 1.5 + 3G0.25
IE2-WU1R 132 M6	4	965	39.6	6.8	4	39.6	7	1800	VSI2.0WSA1-5/0008A	7.5	3 x 1.5 + 3G0.25
IE2-WU2R 132 M6	4	955	40	6.6	4	40	7	2000	VSI2.0WSA1-5/0008A	7.5	3 x 1.5 + 3G0.25
IE2-WU1R 132 MX6	5.5	970	54	9.6	5.5	54	10	2000	VSI2.0WSA1-5/0013A	13	3 x 2.5 + 3G0.5
IE2-WU1R 160 M6	7.5	975	73	12.4	7.5	73	12	2000	VSI2.0WSA1-5/0013A	13	3 x 2.5 + 3G0.5
IE2-WU1R 160 L6	11	970	108	17	11	108	17	2000	VSI2.0WSA1-5/0018A	18	3 x 4 + 3G0.75
IE2-WU1R 180 L6	15	975	147	23	15	147	23	2000	VSI2.0WSA1-5/0026A	26	3 x 6 + 3G1
IE2-WU1R 200 L6	16.5	980	161	26	18.5	180	28	2000	VSI2.0WSA1-5/0031A	31	3 x 10 + 3G1.5
IE2-WU1R 200 LX6	22	980	214	32	22	214	32	2000	VSI2.0WSA1-5/0037A	37	3 x 10 + 3G1.5
IE2-WU1R 225 M6	30	985	291	44	30	291	44	2000	VSI2.0WSA1-5/0046A	46	3 x 16 + 3G2.5
IE2-WU1R 250 M6	37	985	359	54	37	359	54	1800	VSI2.0WSA1-5/0061A	61	3 x 25 + 3G4
IE2-WU1R 280 S6	45	983	437	64	45	437	64	1800	VSI2.0WSA1-5/0074A	74	3 x 35 + 3G6
IE2-WU1R 280 M6	55	990	531	80	55	531	80	1900	VSI2.0WSA1-6/0090A	90	3 x 50 + 3G10
IE2-WU1R 315 S6	75	990	723	106	75	723	106	1900	VSI2.0WSA1-6/0109A	109	3 x 70 + 3G10
IE2-WU1R 315 M6	90	990	868	126	90	868	126	1900	VSI2.0WSA1-6/0146A	146	3 x 95 + 3G16
IE2-WU1R 315 MX6	110	990	1061	155	110	1061	155	1700	VSI2.0WSA1-6/0175A	175	3 x 120 + 3G16
IE2-WU1R 315 MY6	132	990	1273	185	132	1273	185	1600	VSI2.0WSA1-6/0200A	200	3 x 150 + 3G25
IE2-WU1R 315 L6	160	990	1543	222	160	1543	222	1800	VSI2.0CSA1-6/0250A	250	2 x (3 x 70 + 3G10)
IE2-WU1R 315 LX6	200	990	1929	282	185	1784	258	1800	VSI2.0CSA1-6/0300A	300	2 x (3 x 95 + 3G16)
IE2-WU2R 355 MY6	200	990	1929	290	200	1929	290	1600	VSI2.0CSA1-6/0300A	300	2 x (3 x 95 + 3G16)
IE2-WU2R 355 M6	250	994	2402	362	250	2402	371	1600	VSI2.0CSA1-6/0375A	375	2 x (3 x 150 + 3G25)
IE2-WU2R 355 MX6	315	995	3023	444	300	2879	433	1600	VSI2.0CSA1-6/0500A	500	3 x (3 x 120 + 3G16)
IE2-WU2R 355 LY6	355	995	3407	560	315	3023	486	1600	VSI2.0CSA1-6/0595A	600	3 x (3 x 150 + 3G25)
<b>IE3</b>											
IE3-WU2R 400 MY6	355	995	3407	506	355	3407	506	1600	VSI2.0CSA1-6/0600A	600	3 x (3 x 150 + 3G25)
IE3-WU2R 400 M6	400	993	3847	557	355	3407	506	1600	VSI2.0CSA1-6/0600A	600	3 x (3 x 150 + 3G25)
IE3-WU2R 400 MX6	450	993	4327	657	400	A	A	A	VSI2.0CSA1-6/0720A	720	4 x (3 x 150 + 3G25)
IE3-WU2R 400 L6	500	993	4808	728	450	A	A	A	VSI2.0CSA1-6/0800A	800	4 x (3 x 150 + 3G25)
IE3-WU2R 450 M6	560	993	5385	778	A	A	A	A	VSI2.0CSA1-6/0800A	800	4 x (3 x 150 + 3G25)
IE3-WU2R 450 MX6	630	994	6052	897	A	A	A	A	VSI2.0CSA1-6/0995A	1000	5 x (3 x 150 + 3G25)
IE3-WU2R 450 L6	710	994	6821	1011	A	A	A	A	VSI2.0CSA1-6/0995A	1000	5 x (3 x 150 + 3G25)

Withstand voltage  $\hat{U}_{LL} \leq 1560 \text{ V}$

... 1--: Standard Dynamic (SD)

A = by request

Motor sizes > 450 by request

All motors can be supplied with optional forced ventilation at additional cost.

The "R" (rib-cooled with self-ventilation) in the type designation is to be replaced with "F" (forced ventilation).



## Technical data/selection tables

with self-ventilated 6-pole energy-saving motors, series IE2-WU.R with reinforced insulation for heavy duty (overload 150 %. 1 minute every 10 minutes)

IE2 motors (for 50 Hz mains operation) for the output range from 0.18 kW to 355 kW

IE3 motors (for 50 Hz mains operation) for the output range from 355 to 710 kW (size 400 and 450)

Mains voltage: 500 V

Type designation	Mains operation 50 Hz				Inverter-fed operation							Mechanical limit speed	Maximum speed for P = constant	Inverter	Current	Recommended cross-sections for motor connection cable	
	Control range	Speed range			1:2.5	1:5	1:10		400 – 1000 rpm		200 – 1000 rpm						100 – 1000 rpm
Ü <sub>LL</sub> ≤ 1800 V	Rated motor output	Rated motor speed	Rated motor torque	Rated motor current	Motor output	Motor torque	Motor output	Motor torque	Motor output	Motor torque	Motor output	Motor torque	Motor current by 500 V	Type		A	mm <sup>2</sup>
	P/kW	n/ rpm	M/ Nm	A (500 V)	P/ kW	M/ Nm	P/ kW	M/ Nm	P/ kW	M/ Nm	P/ kW	M/ Nm	A	rpm	rpm		
IE2-WU1R 71 K6	0.18	930	1.9	0.46	0.18	1.9	0.18	1.9	0.16	1.7	0.46	11000	2000	A			
IE2-WU1R 71 G6	0.25	935	2.6	0.6	0.25	2.6	0.25	2.6	0.23	2.3	0.6	11000	2000	A			
IE2-WU1R 80 K6	0.37	950	3.7	0.82	0.37	3.7	0.37	3.7	0.33	3.4	0.82	10000	2000	A			
IE2-WU1R 80 G6	0.55	950	5.5	1.2	0.55	5.5	0.55	5.5	0.5	5.0	1.2	10000	2000	A			
IE2-WU1R 90 S6	0.75	955	7.5	1.6	0.75	7.5	0.75	7.5	0.68	6.8	1.6	9000	2000	VSI2.0WSA_-5/0003A	2	3 x 1.5 + 3G0.25	
IE2-WU1R 90 L6	1.1	955	11	2.2	1.1	11	1.1	11	1	9.9	2.2	9000	2000	VSI2.0WSA_-5/0004A	3.2	3 x 1.5 + 3G0.25	
IE2-WU1R 100 LX6	1.5	955	15	2.8	1.5	15	1.5	15	1.4	13.5	2.8	6000	2000	VSI2.0WSA_-5/0004A	3.2	3 x 1.5 + 3G0.25	
IE2-WU1R 112 MV6	2.2	955	22	4.1	2.2	22	2.2	22	2	19.8	A	6000	2000	VSI2.0WSA_-5/0008A	6	3 x 1.5 + 3G0.25	
IE2-WU1R 112 MZ6	3	955	30	5.7	3	30	3	30	2.7	27	5.7	6000	2000	VSI2.0WSA_-5/0008A	6	3 x 1.5 + 3G0.25	
IE2-WU1R 132 S6	3	963	29.8	5.1	3	29.8	3	30	2.9	29	5.1	2400	2000	VSI2.0WSA_-5/0008A	6	3 x 1.5 + 3G0.25	
IE2-WU1R 132 M6	4	965	39.6	6.8	4	39.6	4	40	3.8	38	6.8	2400	1800	VSI2.0WSA_-5/0010A	7.6	3 x 1.5 + 3G0.25	
IE2-WU2R 132 M6	4	955	40	6.6	4	40	3.5	35	3.8	38	6.6	2400	2000	VSI2.0WSA_-5/0010A	7.6	3 x 1.5 + 3G0.25	
IE2-WU1R 132 MX6	5.5	970	54	10	5.5	54	5.5	54	5.2	51	10	2400	2000	VSI2.0WSA_-5/0013A	10.4	3 x 2.5 + 3G0.5	
IE2-WU1R 160 M6	7.5	975	73	12	7.5	73	7.5	73	7.1	70	12	2400	2000	VSI2.0WSA_-5/0018A	14.4	3 x 4 + 3G0.75	
IE2-WU1R 160 L6	11	970	108	17	11	108	11	108	10.5	103	17	2000	2000	VSI2.0WSA_-5/0026A	21	3 x 6 + 3G1	
IE2-WU1R 180 L6	15	975	147	23	15	147	15	147	14.3	140	23	2000	2000	VSI2.0WSA_-5/0031A	25	3 x 10 + 3G1.5	
IE2-WU1R 200 L6	16.5	980	161	26	18.5	180	18.5	180	17.6	172	26	2000	2000	VSI2.0WSA_-5/0037A	29.6	3 x 10 + 3G1.5	
IE2-WU1R 200 LX6	22	980	214	32	22	214	22	214	20.9	204	32	2000	2000	VSI2.0WSA_-5/0046A	37	3 x 16 + 3G2.5	
IE2-WU1R 225 M6	30	985	291	44	30	291	30	291	28.5	276	44	2000	2000	VSI2.0WSA_-5/0061A	49	3 x 25 + 3G4	
IE2-WU1R 250 M6	37	985	359	54	37	359	37	359	35.2	341	54	2000	1800	VSI2.0WSA_-5/0074A	59	3 x 35 + 3G6	
IE2-WU1R 280 S6	45	983	437	64	45	437	45	437	42.8	416	64	2000	1800	VSI2.0WSA_-6/0090A	72	3 x 50 + 3G10	
IE2-WU1R 280 M6	55	990	531	80	55	531	55	531	52.3	505	80	2000	1900	VSI2.0WSA_-6/0109A	87	3 x 70 + 3G10	
IE2-WU1R 315 S6	75	990	723	106	75	723	75	723	71.3	688	106	2000	1900	VSI2.0WSA_-6/0146A	117	3 x 95 + 3G16	
IE2-WU1R 315 M6	90	990	868	126	90	868	90	868	85.5	825	126	2000	1900	VSI2.0WSA_-6/0175A	140	3 x 120 + 3G16	
IE2-WU1R 315 MX6	110	990	1061	155	110	1061	107	1032	104.5	1008	155	2000	1700	VSI2.0WSA_-6/0200A	160	3 x 150 + 3G25	
IE2-WU1R 315 MY6	132	990	1273	185	132	1273	132	1273	125.4	1210	185	2000	1600	VSI2.0CSA_-6/0250A	200	2 x (3 x 70 + 3G10)	
IE2-WU1R 315 L6	160	990	1543	222	160	1543	160	1543	152	1466	222	2000	1800	VSI2.0CSA_-6/0300A	240	2 x (3 x 95 + 3G16)	
IE2-WU1R 315 LX6	200	990	1929	282	185	1784	185	1784	170	1640	258	2000	1800	VSI2.0CSA_-6/0375A	300	2 x (3 x 150 + 3G25)	
IE2-WU2R 355 MY6	200	990	1929	290	200	1929	200	1929	185	1784	290	2000	1600	VSI2.0CSA_-6/0375A	300	2 x (3 x 150 + 3G25)	
IE2-WU2R 355 M6	250	994	2402	362	250	2402	250	2402	235	2258	371	2000	1600	VSI2.0CSA_-6/0500A	400	3 x (3 x 120 + 3G16)	
IE2-WU2R 355 MX6	315	995	3023	444	300	2880	300	2880	290	2781	433	2000	1600	VSI2.0CSA_-6/0595A	480	3 x (3 x 150 + 3G25)	
IE2-WU2R 355 LY6	355	995	3407	560	315	3023	315	3023	315	3023	486	2000	1600	VSI2.0CSA_-6/0650A	520	4 x (3 x 120 + 3G16)	
<b>IE3</b>																	
IE3-WU2R 400 MY6	355	995	3407	506	355	3407	A	A	A	A	506	A	A	VSI2.0CSA_-6/0650A	520	4 x (3 x 120 + 3G16)	
IE3-WU2R 400 M6	400	993	3847	557	355	3407	A	A	A	A	506	A	A	VSI2.0CSA_-6/0650A	520	4 x (3 x 120 + 3G16)	
IE3-WU2R 400 MX6	450	993	4327	657	400	A	A	A	A	A	A	A	A	VSI2.0CSA_-6/0800A	640	4 x (3 x 150 + 3G25)	
IE3-WU2R 400 L6	500	993	4808	728	450	A	A	A	A	A	A	A	A	VSI2.0CSA_-6/0995A	800	5 x (3 x 150 + 3G25)	
IE3-WU2R 450 M6	560	993	5385	778	A	A	A	A	A	A	A	A	A	VSI2.0CSA_-6/0995A	800	5 x (3 x 150 + 3G25)	
IE3-WU2R 450 MX6	630	994	6052	897	A	A	A	A	A	A	A	A	A	VSI2.0CSA_-6/1200A	960	6 x (3 x 150 + 3G25)	
IE3-WU2R 450 L6	710	994	6821	1011	A	A	A	A	A	A	A	A	A	VSI2.0CSA_-6/1400A	1120	7 x (3 x 150 + 3G25)	

Withstand voltage Ü<sub>LL</sub> ≤ 1560 V

depending on requirements  
 ... 1-: Standard Dynamic (SD) or  
 ... 2-: High Dynamic (HD)

A = by request

Motor sizes > 450 by request

All motors can be supplied with optional forced ventilation at additional cost.

The "R" (rib-cooled with self-ventilation) in the type designation is to be replaced with "F" (forced ventilation).

## Technical data/selection tables

with self-ventilated 2-pole energy-saving motors, series IE2-WU.R with reinforced insulation for normal operation (overload 120 %, 1 minute every 10 minutes)

IE2 motors (for 50 Hz mains operation) for the output range from 0.75 kW to 500 kW

IE3 motors (for 50 Hz mains operation) for the output range from 560 to 1000 kW (size 400 and 450)

Mains voltage: 690 V

Type designation	Mains operation 50 Hz				Inverter-fed operation 50 Hz			Maximum speed for P = constant	Inverter	du/dt filter	Current	Recommended cross-sections for motor connection cable
	Rated motor output	Rated motor speed	Rated motor torque	Rated motor current	Motor output	Motor torque	Motor current					
$\hat{U}_{LL} \leq 1800$ V	P/kW	n/rpm	M/Nm	A (690 V)	P/kW	M/Nm	A (690 V)	rpm			A	mm <sup>2</sup>
IE2-WU1R 80 K2	0.75	2880	2.49	0.85	0.75	2.49	0.85	6000	A	x		
IE2-WU1R 80 G2	1.1	2885	3.64	1.2	1.1	3.64	1.2	6000	A	x		
IE2-WU1R 90 S2	1.5	2910	4.92	1.7	1.5	4.92	1.7	6000	A	x		
IE2-WU1R 90 L2	2.2	2880	7.29	2.5	2.2	7.29	2.5	6000	A	x		
IE2-WU1R 100 L2	3	2930	9.78	3.8	3	9.78	3.8	6000	A	x		
IE2-WU1R 112 MX2	4	2920	13.08	4.6	4	13.08	4.6	6000	A	x		
IE2-WU1R 112 MV2	5.5	2900	18.1	5.9	5.5	18.1	5.9	6000	A	x		
IE2-WU1R 132 S2T	5.5	2900	18.1	5.9	5.5	18.1	5.9	6000	A	x		
IE2-WU1R 132 S2	5.5	2915	18	6.1	5.5	18	6.1	6000	A	x		
IE2-WU1R 132 SX2	7.5	2920	24.5	7.8	7.5	24.5	7.8	6000	A	x		
IE2-WU1R 160 M2	11	2940	35.7	11	11	35.6	11	6000	A	x		
IE2-WU1R 160 MX2	15	2935	48.8	15	15	48.7	15	6000	A	x		
IE2-WU1R 160 L2	18.5	2935	60.2	19	18.5	60.2	19	6000	A	x		
IE2-WU1R 180 M2	22	2940	71	22	22	72	22	5400	A	x		
IE2-WU2R 200 LX2	37	2955	120	37	37	120	37	6000	A	x		
IE2-WU1R 225 M2	45	2950	146	46	45	146	46.5	5000	A	x		
IE2-WU1R 250 M2	55	2956	178	55	55	178	55	4500	A	x		
IE2-WU1R 280 S2	75	2970	241	74	75	241	74	4300	VSI2.0WSA1-6/0090A	x	90	3 x 50 + 3G10
IE2-WU1R 280 M2	90	2970	289	88	90	289	88	4300	VSI2.0WSA1-6/0109A	x	109	3 x 70 + 3G10
IE2-WU1R 315 S2	110	2975	353	109	110	353	109	3800	VSI2.0WSA1-6/0146A	x	146	3 x 95 + 3G16
IE2-WU1R 315 M2	132	2975	424	130	132	424	130	3800	VSI2.0WSA1-6/0146A	x	146	3 x 95 + 3G16
IE2-WU1R 315 MX2	160	2973	514	158	160	514	158	3600	VSI2.0WSA1-6/0175A	x	175	3 x 120 + 3G16
IE2-WU1R 315 MY2	200	2983	640	199	200	640	199	3600	VSI2.0CSA1-6/0250A	x	250	2 x (3 x 70 + 3G10)
IE2-WU1R 315 L2	250	2984	800	237	220	704	206	3600	VSI2.0CSA1-6/0250A	x	250	2 x (3 x 70 + 3G10)
IE2-WU1R 315 LX2	315	2985	1008	299	270	864	253	3600	VSI2.0CSA1-6/0300A	x	300	2 x (3 x 95 + 3G16)
IE2-WU2R 355 MY2	315	2988	1008	308	315	1008	308	3600	VSI2.0CSA1-6/0375A	x	375	2 x (3 x 150 + 3G25)
IE2-WU2R 355 M2	355	2985	1136	337	330	1056	313	3600	VSI2.0CSA1-6/0375A	x	375	2 x (3 x 150 + 3G25)
IE2-WU2R 355 MX2	400	2990	1278	383	355	1134	339	3600	VSI2.0CSA1-6/0375A	x	375	2 x (3 x 150 + 3G25)
IE2-WU2R 355 LY2	450	2985	1440	427	425	1360	404	3600	VSI2.0CSA1-6/0430A	x	430	3 x (3 x 95 + 3G16)
IE2-WU2R 355 L2	500	2990	1597	474	425	1357	404	3600	VSI2.0CSA1-6/0430A	x	430	3 x (3 x 95 + 3G16)
<b>IE3</b>												
IE3-WU2R 400 M2	560	2988	1790	557	A	A	A	A	VSI2.0CSA1-6/0595A	x	600	3 x (3 x 150 + 3G25)
IE3-WU2R 400 MX2	630	2988	2014	618	A	A	A	A	VSI2.0CSA1-6/0650A	x	650	4 x (3 x 120 + 3G16)
IE3-WU2R 400 L2	710	2988	2269	690	A	A	A	A	VSI2.0CSA1-6/0720A	x	720	4 x (3 x 150 + 3G25)
IE3-WU2R 450 M2	800	2988	2557	791	A	A	A	A	VSI2.0CSA1-6/0800A	x	800	4 x (3 x 150 + 3G25)
IE3-WU2R 450 MX2	900	2988	2876	889	A	A	A	A	VSI2.0CSA1-6/0905A	x	900	5 x (3 x 120 + 3G16)
IE3-WU2R 450 L2	1000	2990	3194	967	A	A	A	A	VSI2.0CSA1-6/0995A	x	1000	5 x (3 x 150 + 3G25)

Withstand voltage  $\hat{U}_{LL} \leq 1560$  V

... 1--: Standard Dynamic (SD)

A = by request

x = Filter required at the inverter output to reduce pulse voltages

Motor sizes > 450 by request

All motors can be supplied with optional forced ventilation at additional cost.

The "R" (rib-cooled with self-ventilation) in the type designation is to be replaced with "F" (forced ventilation)

## Technical data/selection tables

with self-ventilated 6-pole energy-saving motors, series IE2-WU.R with reinforced insulation for heavy duty (overload 150 %, 1 minute every 10 minutes)

IE2 motors (for 50 Hz mains operation) for the output range from 0.75 kW to 500 kW

IE3 motors (for 50 Hz mains operation) for the output range from 560 to 1000 kW (size 400 and 450)

Mains voltage: 690 V

Type designation	Mains operation 50 Hz				Inverter-fed operation								Mechanical limit speed	Maximum speed for P = constant	Inverter	du/dt filter	Current	Recommended cross-sections for motor connection cable
	Control range	Speed range			1:2.5	1:5	1:10			1200 – 3000 min <sup>-1</sup>	600 – 3000 min <sup>-1</sup>	300 – 3000 min <sup>-1</sup>						
Ü <sub>LL</sub> ≤ 1800 V	Rated motor output	Rated motor speed	Rated motor torque	Rated motor current	Motor output	Motor torque	Motor output	Motor torque	Motor output	Motor torque	Motor output	Motor torque	Motor current by 690 V	Type		A	mm <sup>2</sup>	
	P/kW	n/rpm	M/Nm	A (690 V)	P/kW	M/Nm	P/kW	M/Nm	P/kW	M/Nm	P/kW	M/Nm	A	rpm	rpm			
IE2-WU1R 80 K2	0.75	2880	2.49	0.85	0.75	2.49	0.75	2.49	0.6	1.99	0.85	13000	6000	A	x			
IE2-WU1R 80 G2	1.1	2885	3.64	1.2	1.1	3.64	1.1	3.64	0.9	2.98	1.2	13000	6000	A	x			
IE2-WU1R 90 S2	1.5	2910	4.92	1.7	1.5	4.92	1.5	4.92	1.2	3.94	1.7	11000	6000	A	x			
IE2-WU1R 90 L2	2.2	2880	7.29	2.5	2.2	7.29	2.2	7.29	1.8	5.97	2.5	11000	6000	A	x			
IE2-WU1R 100 L2	3	2930	9.78	3.8	3	9.78	3	9.78	2.4	7.88	3.8	10000	6000	A	x			
IE2-WU1R 112 MX2	4	2920	13.08	4.6	4	13.08	4	13.1	3.2	10.5	4.6	7000	6000	A	x			
IE2-WU1R 112 MV2	5.5	2900	18.1	5.9	5.5	18.11	5.5	18.11	4.4	14.5	5.9	7000	6000	A	x			
IE2-WU1R 132 S2T	5.5	2900	18.1	5.9	5.5	18.1	5.5	18.1	4.4	14.5	5.9	7000	6000	A	x			
IE2-WU1R 132 S2	5.5	2915	18	6.1	5.5	18	5.5	18	5.2	17	6.1	7000	6000	A	x			
IE2-WU1R 132 SX2	7.5	2920	24.5	8	7.5	24.5	7.5	24	7.1	23	8	7000	6000	A	x			
IE2-WU1R 160 M2	11	2940	35.7	11	11	35.6	11	36	10.5	34	11	7000	6000	A	x			
IE2-WU1R 160 MX2	15	2935	48.8	15	15	48.7	15	49	14.3	46	15	6000	6000	A	x			
IE2-WU1R 160 L2	18.5	2935	60.2	19	18.5	60.2	18.5	60	17.6	57	19	6000	6000	A	x			
IE2-WU1R 180 M2	22	2940	71	22	22	72	22	72	20.9	68	22	6000	5400	A	x			
IE2-WU2R 200 LX2	37	2955	120	37	37	120	37	120	35.2	114	37	6000	6000	A	x			
IE2-WU1R 225 M2	45	2950	146	46	45	146	45	146	42.8	139	47	5000	5000	A	x			
IE2-WU1R 250 M2	55	2956	178	55	55	178	55	178	52.3	169	55	4500	4500	A	x			
IE2-WU1R 280 S2	75	2970	241	74	75	241	75	241	71.3	229	74	4300	4300	VSI2.0WSA_-6/0090A	x	72	3 x 50 + 3G10	
IE2-WU1R 280 M2	87	2970	289	88	90	289	90	289	85.5	275	88	4300	4300	VSI2.0WSA_-6/0109A	x	87	3 x 70 + 3G10	
IE2-WU1R 315 S2	110	2975	353	109	110	353	110	354	110	354	109	3800	3800	VSI2.0WSA_-6/0146A	x	117	3 x 95 + 3G16	
IE2-WU1R 315 M2	132	2975	424	130	132	424	132	424	132	424	130	3800	3800	VSI2.0WSA_-6/0175A	x	140	3 x 120 + 3G16	
IE2-WU1R 315 MX2	160	2973	514	158	160	514	160	514	160	514	158	3600	3600	VSI2.0WSA_-6/0200A	x	160	3 x 150 + 3G25	
IE2-WU1R 315 MY2	200	2983	640	199	192	615	192	615	192	608	199	3600	3600	VSI2.0CSA_-6/0250A	x	200	2 x (3 x 70 + 3G10)	
IE2-WU1R 315 L2	250	2984	800	237	220	704	220	704	220	669	206	3600	3600	VSI2.0CSA_-6/0300A	x	240	2 x (3 x 95 + 3G16)	
IE2-WU1R 315 LX2	315	2985	1008	299	270	864	270	864	270	821	253	3600	3600	VSI2.0CSA_-6/0375A	x	300	2 x (3 x 150 + 3G25)	
IE2-WU2R 355 MY2	315	2988	1008	308	315	1007	315	1007	299	957	308	3600	3600	VSI2.0CSA_-6/0400A	x	320	3 x (3 x 95 + 3G16)	
IE2-WU2R 355 M2	355	2985	1136	337	330	1056	330	1056	306	1003	313	3600	3600	VSI2.0CSA_-6/0400A	x	320	3 x (3 x 95 + 3G16)	
IE2-WU2R 355 MX2	400	2990	1278	383	355	1134	355	1134	355	1077	339	3600	3600	VSI2.0CSA_-6/0430A	x	344	3 x (3 x 95 + 3G16)	
IE2-WU2R 355 LY2	450	2985	1440	427	370	1184	370	1184	370	1184	404	3600	3600	VSI2.0CSA_-6/0500A	x	400	3 x (3 x 120 + 3G16)	
IE2-WU2R 355 L2	500	2990	1597	474	370	1182	370	1182	370	1182	404	3600	3600	VSI2.0CSA_-6/0500A	x	400	3 x (3 x 120 + 3G16)	
<b>IE3</b>																		
IE3-WU2R 400 M2	560	2988	1790	557	A	A	A	A	A	A	A	A	A	VSI2.0CSA_-6/0720A	x	576	4 x (3 x 150 + 3G25)	
IE3-WU2R 400 MX2	630	2988	2014	618	A	A	A	A	A	A	A	A	A	VSI2.0CSA_-6/0800A	x	640	4 x (3 x 150 + 3G25)	
IE3-WU2R 400 L2	710	2988	2269	690	A	A	A	A	A	A	A	A	A	VSI2.0CSA_-6/0905A	x	720	5 x (3 x 150 + 3G25)	
IE3-WU2R 450 M2	800	2988	2557	791	A	A	A	A	A	A	A	A	A	VSI2.0CSA_-6/0995A	x	800	5 x (3 x 150 + 3G25)	
IE3-WU2R 450 MX2	900	2988	2876	889	A	A	A	A	A	A	A	A	A	VSI2.0CSA_-6/1200A	x	960	6 x (3 x 150 + 3G25)	
IE3-WU2R 450 L2	1000	2990	3194	967	A	A	A	A	A	A	A	A	A	VSI2.0CSA_-6/1400A	x	1120	7 x (3 x 150 + 3G25)	

Withstand voltage Ü<sub>LL</sub> ≤ 1560 V

depending on requirements  
 ... 1-: Standard Dynamic (SD) or  
 ... 2-: High Dynamic (HD)

A = by request

x = Filter required at the inverter output to reduce pulse voltages

Motor sizes > 450 by request

All motors can be supplied with optional forced ventilation at additional cost.

The "R" (rib-cooled with self-ventilation) in the type designation is to be replaced with "F" (forced ventilation)

## Technical data/selection tables

with self-ventilated 4-pole energy-saving motors, series IE2-WU.R with reinforced insulation for normal operation (overload 120 %, 1 minute every 10 minutes)

IE2 motors (for 50 Hz mains operation) for the output range from 0.75 kW to 500 kW

IE3 motors (for 50 Hz mains operation) for the output range from 560 to 1000 kW (size 400 and 450)

Mains voltage: 690 V

Type designation	Mains operation 50 Hz				Inverter-fed operation 50 Hz			Maximum speed for P = constant	Inverter	du/dt filter	Current	Recommended cross-sections for motor connection cable
	Rated motor output	Rated motor speed	Rated motor torque	Rated motor current	Motor output	Motor torque	Motor current					
$\hat{U}_{LL} \leq 1800$ V	P/kW	n/rpm	M/Nm	A (690 V)	P/kW	M/Nm	A (690 V)	rpm			A	mm <sup>2</sup>
IE2-WU1R 80 G4	0.75	1430	5.01	1	0.75	5.01	1	3000	A	x		
IE2-WU1R 90 S4	1.1	1435	7.32	1.4	1.1	7.32	1.4	3000	A	x		
IE2-WU1R 90 L4	1.5	1445	9.91	1.9	1.5	9.91	1.9	3000	A	x		
IE2-WU1R 100 L4	2.2	1455	14.4	2.8	2.2	14.4	2.8	3000	A	x		
IE2-WU1R 100 LX4	3	1455	19.7	3.8	3	19.7	3.8	3000	A	x		
IE2-WU1R 112 MZ4	4	1445	26.4	4.8	4	26.4	4.8	3000	A	x		
IE2-WU1R 112 M4	4	1460	26.2	4.4	4	26.2	4.4	3000	A	x		
IE2-WU1R 132 S4	5.5	1465	35.9	6	5.5	35.7	6	3000	A	x		
IE2-WU2R 132 S4	5.5	1450	36.2	6	5.5	36.2	6	3000	A	x		
IE2-WU1R 132 M4	7.5	1470	48.7	9	7.5	48.7	8	3000	A	x		
IE2-WU1R 160 M4	11	1475	71	12	11	71	12	3000	A	x		
IE2-WU2R 160 L4	15	1475	97	16	15	97	16	3000	A	x		
IE2-WU1R 180 M4	18.5	1475	120	20	18.5	120	20	3000	A	x		
IE2-WU1R 180 L4	22	1475	142	25	22	142	24	3000	A	x		
IE2-WU1R 200 L4	30	1480	194	34	30	194	34	3000	A	x		
IE2-WU1R 225 S4	37	1475	240	40	37	240	40	3000	A	x		
IE2-WU1R 225 M4	45	1483	290	48	45	290	48	2600	A	x		
IE2-WU1R 250 M4	55	1485	354	58	55	354	58	2600	A	x		
IE2-WU1R 280 S4	75	1485	482	79	75	482	79	2400	VSI2.0WSA1-6/0090A	x	90	3 x 50+3G10
IE2-WU1R 280 M4	90	1483	580	95	90	580	95	2600	VSI2.0WSA1-6/0109A	x	109	3 x 70+3G10
IE2-WU1R 315 S4	110	1485	707	118	110	707	118	3000	VSI2.0WSA1-6/0146A	x	146	3 x 95+3G16
IE2-WU1R 315 M4	132	1484	849	140	132	849	140	2600	VSI2.0WSA1-6/0146A	x	146	3 x 95+3G16
IE2-WU1R 315 MX4	160	1482	1031	167	160	1031	167	2500	VSI2.0WSA1-6/0175A	x	175	3 x 120+3G16
IE2-WU1R 315 MY4	200	1490	1282	201	200	1282	198	2800	VSI2.0CSA1-6/0250A	x	250	2 x (3 x 70+3G10)
IE2-WU1R 315 L4	250	1490	1602	248	250	1608	241	3000	VSI2.0CSA1-6/0250A	x	250	2 x (3 x 70+3G10)
IE2-WU1R 315 LX4	315	1490	2019	313	285	1827	279	3000	VSI2.0CSA1-6/0300A	x	300	2 x (3 x 95+3G16)
IE2-WU2R 355 MY4	315	1491	2019	323	315	2019	323	3000	VSI2.0CSA1-6/0375A	x	375	2 x (3 x 150+3G25)
IE2-WU2R 355 M4	355	1493	2271	356	355	2271	364	3000	VSI2.0CSA1-6/0375A	x	375	2 x (3 x 150+3G25)
IE2-WU2R 355 MX4	400	1494	2557	397	390	2493	400	3000	VSI2.0CSA1-6/0430A	x	430	3 x (3 x 95+3G16)
IE2-WU2R 355 LY4	450	1496	2873	457	430	2745	452	3000	VSI2.0CSA1-6/0500A	x	500	3 x (3 x 120+3G16)
IE2-WU2R 355 L4	500	1493	3198	520	430	2745	447	3000	VSI2.0CSA1-6/0500A	x	500	3 x (3 x 120+3G16)
<b>IE3</b>												
IE3-WU2R 400 M4	560	1493	3582	581	A	A	A	A	VSI2.0CSA1-6/0595A	x	600	3 x (3 x 150+3G25)
IE3-WU2R 400 MX4	630	1493	4030	646	A	A	A	A	VSI2.0CSA1-6/0650A	x	650	4 x (3 x 120+3G16)
IE3-WU2R 400 L4	710	1493	4542	728	A	A	A	A	VSI2.0CSA1-6/0720A	x	720	4 x (3 x 150+3G25)
IE3-WU2R 450 M4	800	1493	5117	830	A	A	A	A	VSI2.0CSA1-6/0800A	x	800	4 x (3 x 150+3G25)
IE3-WU2R 450 MX4	900	1493	5757	912	A	A	A	A	VSI2.0CSA1-6/0905A	x	900	5 x (3 x 120+3G16)
IE3-WU2R 450 L4	1000	1493	6397	1013	A	A	A	A	VSI2.0CSA1-6/0995A	x	1000	5 x (3 x 150+3G25)

Withstand voltage  $\hat{U}_{LL} \leq 1560$  V

... 1-: Standard Dynamic (SD)

A = by request

x = Filter required at the inverter output to reduce pulse voltages

Motor sizes > 450 by request

All motors can be supplied with optional forced ventilation at additional cost.

The "R" (rib-cooled with self-ventilation) in the type designation is to be replaced with "F" (forced ventilation).

## Technical data/selection tables

with self-ventilated 4-pole energy-saving motors, series IE2-WU.R with reinforced insulation for heavy duty (overload 150 %, 1 minute every 10 minutes)

IE2 motors (for 50 Hz mains operation) for the output range from 0.75 kW to 500 kW

IE3 motors (for 50 Hz mains operation) for the output range from 560 to 1000 kW (size 400 and 450)

Mains voltage: 690 V

Type designation	Mains operation 50 Hz				Inverter-fed operation								Mechanical limit speed	Maximum speed for P = constant	Inverter	du/dt filter	Current	Recommended cross-sections for motor connection cable
	Control range	Speed range			1:2.5	1:5	1:10		600 – 1500 min <sup>-1</sup>		300 – 1500 min <sup>-1</sup>							
Ü <sub>LL</sub> ≤ 1800 V	Rated motor output	Rated motor speed	Rated motor torque	Rated motor current	Motor output	Motor torque	Motor output	Motor torque	Motor output	Motor torque	Motor output	Motor torque	Motor current by 690 V	Type		A	mm <sup>2</sup>	
	P/kW	n/ rpm	M/ Nm	A (690 V)	P/ kW	M/ Nm	P/ kW	M/ Nm	P/ kW	M/ Nm	P/ kW	M/ Nm	A	rpm	rpm			
IE2-WU1R 80 G4	0.75	1430	5.0	1	0.75	5.0	0.75	5.01	0.6	4.01	1	11000	3000	A	x			
IE2-WU1R 90 S4	1.1	1435	7.3	1.4	1.1	7.3	1.1	7.32	0.9	5.99	1.4	9000	3000	A	x			
IE2-WU1R 90 L4	1.5	1445	9.9	1.9	1.5	9.9	1.5	9.91	1.2	7.93	1.9	9000	3000	A	x			
IE2-WU1R 100 L4	2.2	1455	14.4	2.8	2.2	14.4	2.2	14.4	1.8	11.81	2.8	8000	3000	A	x			
IE2-WU1R 100 LX4	3	1455	19.7	3.8	3	19.7	3	19.7	2.4	15.8	3.8	6000	3000	A	x			
IE2-WU1R 112 MZ4	4	1445	26.4	4.8	4	26.4	4	26.4	3.2	21.1	4.8	6000	3000	A	x			
IE2-WU1R 112 M4	4	1460	26.2	4.4	4	26.2	3.7	24	3.8	25	4.4	6000	3000	A	x			
IE2-WU1R 132 S4	5.5	1465	35.9	6.1	5.5	35.7	5.5	36	5.2	34	5.8	3600	3000	A	x			
IE2-WU2R 132 S4	5.5	1450	36.2	6.1	5.5	36.2	5	33	5.2	34	6.1	3600	3000	A	x			
IE2-WU1R 132 M4	7.5	1470	48.7	8.7	7.5	48.7	7.5	49	7.1	46	8.4	3600	3000	A	x			
IE2-WU1R 160 M4	11	1475	71	12	11	71	11	71	10.5	68	12	3600	3000	A	x			
IE2-WU2R 160 L4	15	1475	97	16	15	97	15	97	14.3	92	16	3600	3000	A	x			
IE2-WU1R 180 M4	18.5	1475	120	20	18.5	120	18.5	120	17.6	114	20	3000	3000	A	x			
IE2-WU1R 180 L4	22	1475	142	25	22	142	22	142	20.9	135	24	3000	3000	A	x			
IE2-WU1R 200 L4	30	1480	194	34	30	194	30	194	28.5	184	34	3000	3000	A	x			
IE2-WU1R 225 S4	37	1475	240	40	37	240	37	240	35.2	228	40	3000	3000	A	x			
IE2-WU1R 225 M4	45	1483	290	48	45	290	45	290	42.8	276	48	3000	2600	A	x			
IE2-WU1R 250 M4	55	1485	354	58	55	354	55	354	52.3	336	58	3000	2600	VSI2.0WSA_-6/0090A	x	72	3 x 50 + 3G10	
IE2-WU1R 280 S4	75	1485	482	79	75	482	75	482	71.3	459	79	3000	2400	VSI2.0WSA_-6/0109A	x	87	3 x 70 + 3G10	
IE2-WU1R 280 M4	90	1483	580	95	90	580	90	580	85.5	551	95	3000	2600	VSI2.0WSA_-6/0146A	x	117	3 x 95 + 3G16	
IE2-WU1R 315 S4	110	1485	707	118	110	707	110	707	104.5	672	118	3000	3000	VSI2.0WSA_-6/0146A	x	117	3 x 95 + 3G16	
IE2-WU1R 315 M4	132	1484	849	140	132	849	132	849	125.4	807	140	3000	2600	VSI2.0WSA_-6/0175A	x	140	3 x 120 + 3G16	
IE2-WU1R 315 MX4	160	1482	1031	167	160	1031	160	1031	152	979	167	3000	2500	VSI2.0WSA_-6/0200A	x	160	3 x 150 + 3G25	
IE2-WU1R 315 MY4	200	1490	1282	201	200	1282	200	1282	190	1218	198	3000	2800	VSI2.0CSA_-6/0250A	x	200	2 x (3 x 70 + 3G10)	
IE2-WU1R 315 L4	250	1490	1602	248	250	1608	250	1602	238	1522	241	3000	3000	VSI2.0CSA_-6/0300A	x	240	2 x (3 x 95 + 3G16)	
IE2-WU1R 315 LX4	315	1490	2019	313	277	1780	277	1775	271	1736	279	3000	3000	VSI2.0CSA_-6/0375A	x	300	2 x (3 x 150 + 3G25)	
IE2-WU2R 355 MY4	315	1491	2019	323	315	2019	315	2019	292	1868	323	3000	3000	VSI2.0CSA_-6/0430A	x	344	3 x (3 x 95 + 3G16)	
IE2-WU2R 355 M4	355	1493	2271	356	355	2275	355	2275	328	2100	364	3000	3000	VSI2.0CSA_-6/0500A	x	400	3 x (3 x 120 + 3G16)	
IE2-WU2R 355 MX4	400	1494	2557	397	390	2500	390	2500	368	2358	400	3000	3000	VSI2.0CSA_-6/0500A	x	400	3 x (3 x 120 + 3G16)	
IE2-WU2R 355 LY4	450	1496	2873	457	430	2756	400	2555	390	2500	452	3000	3000	VSI2.0CSA_-6/0595A	x	480	3 x (3 x 150 + 3G25)	
IE2-WU2R 355 L4	500	1493	3198	520	430	2756	400	2555	390	2500	452	3000	3000	VSI2.0CSA_-6/0595A	x	480	3 x (3 x 150 + 3G25)	
<b>IE3</b>																		
IE3-WU2R 400 M4	560	1493	3582	581	A	A	A	A	A	A	A	A	A	VSI2.0CSA_-6/0720A	x	576	4 x (3 x 150 + 3G25)	
IE3-WU2R 400 MX4	630	1493	4030	646	A	A	A	A	A	A	A	A	A	VSI2.0CSA_-6/0800A	x	640	4 x (3 x 150 + 3G25)	
IE3-WU2R 400 L4	710	1493	4542	728	A	A	A	A	A	A	A	A	A	VSI2.0CSA_-6/0905A	x	720	5 x (3 x 150 + 3G25)	
IE3-WU2R 450 M4	800	1493	5117	830	A	A	A	A	A	A	A	A	A	VSI2.0CSA_-6/0995A	x	800	5 x (3 x 150 + 3G25)	
IE3-WU2R 450 MX4	900	1493	5757	912	A	A	A	A	A	A	A	A	A	VSI2.0CSA_-6/1200A	x	960	6 x (3 x 150 + 3G25)	
IE3-WU2R 450 L4	1000	1493	6397	1013	A	A	A	A	A	A	A	A	A	VSI2.0CSA_-6/1400A	x	1120	7 x (3 x 150 + 3G25)	

Withstand voltage Ü<sub>LL</sub> ≤ 1560 V

depending on requirements  
 ... 1-: Standard Dynamic (SD) or  
 ... 2-: High Dynamic (HD)

A = by request

x = Filter required at the inverter output to reduce pulse voltages

Motor sizes > 450 by request

All motors can be supplied with optional forced ventilation at additional cost.

The "R" (rib-cooled with self-ventilation) in the type designation is to be replaced with "F" (forced ventilation)

## Technical data/selection tables

with self-ventilated 6-pole energy-saving motors, series IE2-WU.R with reinforced insulation for normal operation (overload 120 %, 1 minute every 10 minutes)

IE2 motors (for 50 Hz mains operation) for the output range from 0.75 kW to 355 kW

IE3 motors (for 50 Hz mains operation) for the output range from 355 to 710 kW (size 400 and 450)

Mains voltage: 690 V

Type designation	Mains operation 50 Hz				Inverter-fed operation 50 Hz			Maximum speed for P = constant	Inverter	du/dt filter	Current	Recommended cross-sections for motor connection cable
	Rated motor output	Rated motor speed	Rated motor torque	Rated motor current	Motor output	Motor torque	Motor current					
$\hat{U}_{LL} \leq 1800 \text{ V}$	P/kW	n/rpm	M/Nm	A (690 V)	P/kW	M/Nm	A (690 V)	rpm			A	mm <sup>2</sup>
IE2-WU1R 90 S6	0.75	955	7.5	1.1	0.75	7.5	1.1	2000	A	x		
IE2-WU1R 90 L6	1.1	955	11	1.6	1.1	11	A	2000	A	x		
IE2-WU1R 100 LX6	1.5	955	15	2	1.5	15	2	2000	A	x		
IE2-WU1R 112 MV6	2.2	955	22	3	2.2	22	A	2000	A	x		
IE2-WU1R 112 MZ6	3	955	30	4.1	3	30	A	2000	A	x		
IE2-WU1R 132 S6	3	963	29.8	3.7	3	29.8	3.7	2000	A	x		
IE2-WU1R 132 M6	4	965	39.6	5	4	39.6	5	1800	A	x		
IE2-WU2R 132 M6	4	955	40	5	4	40	5	2000	A	x		
IE2-WU1R 132 MX6	5.5	970	54	7	5.5	54	7	2000	A	x		
IE2-WU1R 160 M6	7.5	975	73	9	7.5	73	9	2000	A	x		
IE2-WU1R 160 L6	11	970	108	12	11	108	12	2000	A	x		
IE2-WU1R 180 L6	15	975	147	16	15	147	17	2000	A	x		
IE2-WU1R 200 L6	16.5	980	161	19	18.5	180	20	2000	A	x		
IE2-WU1R 200 LX6	22	980	214	23	22	214	23	2000	A	x		
IE2-WU1R 225 M6	30	985	291	31	30	291	32	2000	A	x		
IE2-WU1R 250 M6	37	985	359	39	37	359	39	1800	A	x		
IE2-WU1R 280 S6	45	983	437	46	45	437	47	1800	A	x		
IE2-WU1R 280 M6	55	990	531	58	55	531	58	1900	A	x		
IE2-WU1R 315 S6	75	990	723	77	75	723	77	1900	VSI2.0WSA1-6/0090A	x	90	3 x 50 + 3G10
IE2-WU1R 315 M6	90	990	868	91	90	868	91	1900	VSI2.0WSA1-6/0109A	x	109	3 x 70 + 3G10
IE2-WU1R 315 MX6	110	990	1061	112	110	1061	112	1700	VSI2.0WSA1-6/0146A	x	146	3 x 95 + 3G16
IE2-WU1R 315 MY6	132	990	1273	133	132	1273	133	1600	VSI2.0WSA1-6/0146A	x	146	3 x 95 + 3G16
IE2-WU1R 315 L6	160	990	1543	160	160	1543	160	1800	VSI2.0WSA1-6/0175A	x	175	3 x 120 + 3G16
IE2-WU1R 315 LX6	200	990	1929	204	185	1784	187	1800	VSI2.0WSA1-6/0200A	x	200	3 x 150 + 3G25
IE2-WU2R 355 MY6	200	990	1929	209	200	1929	209	1600	VSI2.0CSA1-6/0250A	x	250	2 x (3 x 70 + 3G10)
IE2-WU2R 355 M6	250	994	2402	261	250	2402	268	1600	VSI2.0CSA1-6/0300A	x	300	2 x (3 x 95 + 3G16)
IE2-WU2R 355 MX6	315	995	3023	320	300	2879	312	1600	VSI2.0CSA1-6/0375A	x	375	2 x (3 x 150 + 3G25)
IE2-WU2R 355 LY6	355	995	3407	404	315	3023	351	1600	VSI2.0CSA1-6/0375A	x	375	2 x (3 x 150 + 3G25)
<b>IE3</b>												
IE3-WU2R 400 MY6	355	995	3407	365	355	3407	365	1600	VSI2.0CSA1-6/0375A	x	375	2 x (3 x 150 + 3G25)
IE3-WU2R 400 M6	400	993	3847	402	355	3407	365	1600	VSI2.0CSA1-6/0375A	x	375	2 x (3 x 150 + 3G25)
IE3-WU2R 400 MX6	450	993	4327	474	400	A	A	A	VSI2.0CSA1-6/0430A	x	430	3 x (3 x 95 + 3G16)
IE3-WU2R 400 L6	500	993	4808	526	450	A	A	A	VSI2.0CSA1-6/0500A	x	500	3 x (3 x 120 + 3G16)
IE3-WU2R 450 M6	560	993	5385	562	A	A	A	A	VSI2.0CSA1-6/0595A	x	600	3 x (3 x 150 + 3G25)
IE3-WU2R 450 MX6	630	994	6052	647	A	A	A	A	VSI2.0CSA1-6/0650A	x	650	4 x (3 x 120 + 3G16)
IE3-WU2R 450 L6	710	994	6821	730	A	A	A	A	VSI2.0CSA1-6/0720A	x	720	4 x (3 x 120 + 3G16)

Withstand voltage  $\hat{U}_{LL} \leq 1560 \text{ V}$

... 1-: Standard Dynamic (SD)

A = by request

x = Filter required at the inverter output to reduce pulse voltages

Motor sizes > 450 by request

All motors can be supplied with optional forced ventilation at additional cost.

The "R" (rib-cooled with self-ventilation) in the type designation is to be replaced with "F" (forced ventilation)

## Technical data/selection tables

with self-ventilated 6-pole energy-saving motors, series IE2-WU.R with reinforced insulation for heavy duty (overload 150 %, 1 minute every 10 minutes)

IE2 motors (for 50 Hz mains operation) for the output range from 0.75 kW to 355 kW

IE3 motors (for 50 Hz mains operation) for the output range from 355 to 710 kW (size 400 and 450)

Mains voltage: 690 V

Type designation	Mains operation 50 Hz				Inverter-fed operation								Mechanical limit speed	Maximum speed for P = constant	Inverter	du/dt filter	Current	Recommended cross-sections for motor connection cable
	Control range	Speed range			1:2.5	1:5	1:10			400 – 1000 min <sup>-1</sup>	200 – 1000 min <sup>-1</sup>	100 – 1000 min <sup>-1</sup>						
Ü <sub>LL</sub> ≤ 1800 V	Rated motor output	Rated motor speed	Rated motor torque	Rated motor current	Motor output	Motor torque	Motor output	Motor torque	Motor output	Motor torque	Motor output	Motor torque	Motor current by 690 V	Type		A	mm <sup>2</sup>	
	P/kW	n/ rpm	M/ Nm	A (690 V)	P/ kW	M/ Nm	P/ kW	M/ Nm	P/ kW	M/ Nm	P/ kW	M/ Nm	A	rpm	rpm			
IE2-WU1R 90 S6	0.75	955	7.5	1.1	0.75	7.5	0.75	7.5	0.68	6.75	1.1	9000	2000	A	x			
IE2-WU1R 90 L6	1.1	955	11	1.6	1.1	11	1.1	11	1.0	9.9	A	9000	2000	A	x			
IE2-WU1R 100 LX6	1.5	955	15	2.0	1.5	15	1.5	15	1.4	13.5	2	6000	2000	A	x			
IE2-WU1R 112 MV6	2.2	955	22	3.0	2.2	22	2.2	22	2.0	19.8	A	6000	2000	A	x			
IE2-WU1R 112 MZ6	3	955	30	4.1	3	30	3	30	2.7	27	A	6000	2000	A	x			
IE2-WU1R 132 S6	3	963	29.8	3.7	3	29.8	3	30	2.9	29	3.7	2400	2000	A	x			
IE2-WU1R 132 M6	4	965	39.6	5	4	39.6	4	40	3.8	38	5	2400	1800	A	x			
IE2-WU2R 132 M6	4	955	40	5	4	40	3.5	35	3.8	38	5	2400	2000	A	x			
IE2-WU1R 132 MX6	5.5	970	54	7	5.5	54	5.5	54	5.2	51	7	2400	2000	A	x			
IE2-WU1R 160 M6	7.5	975	73	9	7.5	73	7.5	73	7.1	70	9	2400	2000	A	x			
IE2-WU1R 160 L6	11	970	108	12	11	108	11	108	10.5	103	12	2000	2000	A	x			
IE2-WU1R 180 L6	15	975	147	16	15	147	15	147	14.3	140	17	2000	2000	A	x			
IE2-WU1R 200 L6	16.5	980	161	19	18.5	180	18.5	180	17.6	172	20	2000	2000	A	x			
IE2-WU1R 200 LX6	22	980	214	23	22	214	22	214	20.9	204	23	2000	2000	A	x			
IE2-WU1R 225 M6	30	985	291	31	30	291	30	291	28.5	276	32	2000	2000	A	x			
IE2-WU1R 250 M6	37	985	359	39	37	359	37	359	35.2	341	39	2000	1800	A	x			
IE2-WU1R 280 S6	45	983	437	46	45	437	45	437	42.8	416	47	2000	1800	VS12.0WSA_-6/0090A	x	72	3 x 50 + 3G10	
IE2-WU1R 280 M6	55	990	531	58	55	531	55	531	52.3	505	58	2000	1900	VS12.0WSA_-6/0090A	x	72	3 x 50 + 3G10	
IE2-WU1R 315 S6	75	990	723	77	75	723	75	723	71.3	688	77	2000	1900	VS12.0WSA_-6/0109A	x	87	3 x 70 + 3G10	
IE2-WU1R 315 M6	90	990	868	91	90	868	90	868	85.5	825	91	2000	1900	VS12.0WSA_-6/0146A	x	117	3 x 95 + 3G16	
IE2-WU1R 315 MX6	110	990	1061	112	110	1061	107	1032	104.5	1008	112	2000	1700	VS12.0WSA_-6/0146A	x	117	3 x 95 + 3G16	
IE2-WU1R 315 MY6	132	990	1273	133	132	1273	132	1273	125.4	1210	133	2000	1600	VS12.0WSA_-6/0175A	x	140	3 x 120 + 3G16	
IE2-WU1R 315 L6	160	990	1543	160	160	1543	160	1543	152	1466	160	2000	1800	VS12.0WSA_-6/0200A	x	160	3 x 150 + 3G25	
IE2-WU1R 315 LX6	200	990	1929	204	185	1784	185	1784	170	1640	187	2000	1800	VS12.0CSA_-6/0250A	x	200	2 x (3 x 70 + 3G10)	
IE2-WU2R 355 MY6	200	990	1929	209	200	1929	200	1929	185	1784	209	2000	1600	VS12.0CSA_-6/0300A	x	240	2 x (3 x 95 + 3G16)	
IE2-WU2R 355 M6	250	994	2402	261	250	2402	250	2402	235	2258	268	2000	1600	VS12.0CSA_-6/0375A	x	300	2 x (3 x 150 + 3G25)	
IE2-WU2R 355 MX6	315	995	3023	320	300	2880	300	2880	290	2781	312	2000	1600	VS12.0CSA_-6/0400A	x	320	3 x (3 x 95 + 3G16)	
IE2-WU2R 355 LY6	355	995	3407	404	315	3023	315	3023	315	3023	351	2000	1600	VS12.0CSA_-6/0500A	x	400	3 x (3 x 120 + 3G16)	
<b>IE3</b>																		
IE3-WU2R 400 MY6	355	995	3407	365	355	3407	A	A	A	A	A	A	1600	VS12.0CSA_-6/0500A	x	400	3 x (3 x 120 + 3G16)	
IE3-WU2R 400 M6	400	993	3847	402	355	3407	A	A	A	A	A	A	1600	VS12.0CSA_-6/0500A	x	400	3 x (3 x 120 + 3G16)	
IE3-WU2R 400 MX6	450	993	4327	474	400	A	A	A	A	A	A	A	A	VS12.0CSA_-6/0595A	x	480	3 x (3 x 150 + 3G25)	
IE3-WU2R 400 L6	500	993	4808	526	450	A	A	A	A	A	A	A	A	VS12.0CSA_-6/0650A	x	520	4 x (3 x 120 + 3G16)	
IE3-WU2R 450 M6	560	993	5385	562	A	A	A	A	A	A	A	A	A	VS12.0CSA_-6/0720A	x	576	4 x (3 x 150 + 3G25)	
IE3-WU2R 450 MX6	630	994	6052	647	A	A	A	A	A	A	A	A	A	VS12.0CSA_-6/0800A	x	640	4 x (3 x 150 + 3G25)	
IE3-WU2R 450 L6	710	994	6821	730	A	A	A	A	A	A	A	A	A	VS12.0CSA_-6/0905A	x	720	5 x (3 x 150 + 3G25)	

Withstand voltage Ü<sub>LL</sub> ≤ 1560 V

depending on requirements  
 ... 1-: Standard Dynamic (SD) or  
 ... 2-: High Dynamic (HD)

A = by request

x = Filter required at the inverter output to reduce pulse voltages

Motor sizes > 450 by request

All motors can be supplied with optional forced ventilation at additional cost.

The "R" (rib-cooled with self-ventilation) in the type designation is to be replaced with "F" (forced ventilation)

## Technical data/selection tables

### 2-pole, self-ventilated squirrel-cage motors, series KV.R, with reinforced ventilation

for applications with quadratically increased load torque characteristic (overload 120 %, 1 minute every 10 minutes) Without filter at the inverter output (maximum phase-to-phase pulse voltage: **2.5 kV**)

**Mains voltage: 690 V**

Type designation	Mains operation 50 Hz				Mechanical limit speed rpm	Inverter Type	Current A	Recommended cross-sections for motor connection cable mm <sup>2</sup>
	Motor torque	Motor speed	Motor torque	Motor current				
	P/kW	n/rpm	M/Nm	A (690 V)				
KV1R 132 S2	4	2860	13	4.6	7000	A		
KV1R 132 SX2	5.5	2900	18	5.8	7000	A		
KV1R 160 M2	7.5	2900	25	7.8	7000	A		
KV1R 160 MX2	11	2930	36	12	6000	A		
KV1R 160 L2	15	2920	49	15	6000	A		
KV1R 180 M2	18.5	2935	60	19	6000	A		
KV1R 200 L2	22	2950	72	22	6000	A		
KV1R 200 LX2	30	2955	97	31	6000	A		
KV1R 225 M2	37	2955	120	37	5000	A		
KV1R 250 M2	45	2955	145	45	4500	A		
KV1R 280 S2	55	2970	177	53	4300	A		
KV1R 280 M2	75	2970	241	73	4300	VSI2.0WSA1-6/0090A	90 3 x 50 + 3G10	
KV1R 315 S2	90	2980	289	89	3800	VSI2.0WSA1-6/0090A	90 3 x 50 + 3G10	
KV1R 315 M2	110	2975	353	108	3800	VSI2.0WSA1-6/0109A	109 3 x 70 + 3G10	
KV1R 315 MX2	132	2980	424	131	3600	VSI2.0WSA1-6/0146A	146 3 x 95 + 3G16	
KV1R 315 MY2	160	2980	515	162	3600	VSI2.0WSA1-6/0175A	175 3 x 120 + 3G16	
KV1R 315 L2	200	2980	642	195	3600	VSI2.0WSA1-6/0200A	200 3 x 150 + 3G25	
KV1R 315 LX2	250	2985	803	238	3600	VSI2.0CSA1-6/0250A	250 2 x (3 x 70 + 3G10)	
KV2R 355 MY2	280	2990	897	265	3600	VSI2.0CSA1-6/0300A	300 2 x (3 x 95 + 3G16)	
KV2R 355 M2	300	2985	961	286	3600	VSI2.0CSA1-6/0300A	300 2 x (3 x 95 + 3G16)	
KV2R 355 MX2	340	2990	1088	331	3600	VSI2.0CSA1-6/0375A	375 2 x (3 x 150 + 3G25)	
KV2R 355 LY2	370	2985	1185	354	3600	VSI2.0CSA1-6/0375A	375 2 x (3 x 150 + 3G25)	
KV2R 355 L2	410	2988	1312	391	3600	VSI2.0CSA1-6/0400A	400 2 x (3 x 150 + 3G25)	

A = by request

... 1-: Standard Dynamic (SD)

Motor sizes > 355 by request

All motors can be supplied with optional forced ventilation at additional cost.

The "R" (rib-cooled with self-ventilation) in the type designation is to be replaced with "F" (forced ventilation).



## Technical data/selection tables

### 2-pole, self-ventilated squirrel-cage motors, series KV.R, with reinforced ventilation

for applications with constant torque characteristic (overload 150 %, 1 minute every 10 minutes)

Without filter at the inverter output (maximum phase-to-phase pulse voltage: **2.5 kV**)

**Mains voltage: 690 V**

Type designation	Inverter-fed operation											Mechanical limit speed	Maximum speed for P = constant	Inverter	Current	Recommended cross-sections for motor connection cable	
	Control range		50 Hz		1:2.5		1:5		1:10		Speed range						1200 – 3000 rpm
	Rated motor output	Rated motor speed	Rated motor torque	Rated motor current	Motor output	Motor torque	Motor output	Motor torque	Motor output	Motor torque	Motor current by 690 V	rpm	rpm	Type	A	mm <sup>2</sup>	
	P/kW	n/rpm	M/Nm	A (690 V)	P/kW	M/Nm	P/kW	M/Nm	P/kW	M/Nm	A						
KV1R 132 S2	4	2860	13	4.6	4	13	3.9	13	3.6	12	4.6	7000	5100	A			
KV1R 132 SX2	5.5	2900	18	6	5.5	18	5.4	18	4.9	16	6	7000	5700	A			
KV1R 160 M2	7.5	2900	25	8	7.5	25	7	24	6.8	22	8	7000	6000	A			
KV1R 160 MX2	11	2930	36	12	11	36	11	35	9.9	32	12	6000	6000	A			
KV1R 160 L2	15	2920	49	15	15	49	15	48	13.5	44	15	6000	6000	A			
KV1R 180 M2	18.5	2935	60	19	18.5	60	18	59	16.7	54	19	6000	5900	A			
KV1R 200 L2	22	2950	72	22	22	71	22	70	20	64	22	6000	6000	A			
KV1R 200 LX2	30	2955	97	31	30	97	30	95	27	88	31	6000	5400	A			
KV1R 225 M2	37	2955	120	37	37	120	36	118	33	107	38	5000	5000	A			
KV1R 250 M2	45	2955	145	45	45	145	44	142	41	131	45	4500	4500	VSI2.0WSA_-6/0090A	72	3 x 50 + 3G10	
KV1R 280 S2	55	2970	177	53	55	177	54	173	50	161	53	4300	4300	VSI2.0WSA_-6/0090A	72	3 x 50 + 3G10	
KV1R 280 M2	75	2970	241	73	75	241	74	236	68	217	73	4300	4300	VSI2.0WSA_-6/0109A	87	3 x 70 + 3G10	
KV1R 315 S2	90	2980	289	89	90	289	88	283	82	262	89	3800	3800	VSI2.0WSA_-6/0146A	117	3 x 95 + 3G16	
KV1R 315 M2	110	2975	353	108	110	353	108	346	100	321	108	3800	3800	VSI2.0WSA_-6/0146A	117	3 x 95 + 3G16	
KV1R 315 MX2	132	2980	424	131	132	424	130	415	120	386	131	3600	3600	VSI2.0WSA_-6/0175A	140	3 x 120 + 3G16	
KV1R 315 MY2	160	2980	515	162	160	515	157	504	150	481	163	3600	3600	VSI2.0WSA_-6/0200A	160	3 x 150 + 3G25	
KV1R 315 L2	200	2980	642	195	200	642	196	630	180	578	195	3600	3600	VSI2.0CSA_-6/0250A	200	2 x (3 x 70 + 3G10)	
KV1R 315 LX2	250	2985	803	238	250	803	246	786	226	722	239	3600	3600	VSI2.0CSA_-6/0300A	240	2 x (3 x 95 + 3G16)	
KV2R 355 MY2	280	2990	897	265	280	897	275	879	253	807	265	3600	3600	VSI2.0CSA_-6/0375A	300	2 x (3 x 150 + 3G25)	
KV2R 355 M2	300	2985	961	286	300	961	295	942	271	865	286	3600	3600	VSI2.0CSA_-6/0375A	300	2 x (3 x 150 + 3G25)	
KV2R 355 MX2	340	2990	1088	331	340	1088	334	1066	306	977	332	3600	3600	VSI2.0CSA_-6/0430A	344	3 x (3 x 95 + 3G16)	
KV2R 355 LY2	370	2985	1185	354	370	1185	363	1161	332	1061	354	3600	3600	VSI2.0CSA_-6/0500A	400	3 x (3 x 120 + 3G16)	
KV2R 355 L2	410	2988	1312	391	410	1312	402	1286	372	1187	391	3600	3600	VSI2.0CSA_-6/0500A	400	3 x (3 x 120 + 3G16)	

A = by request

Motor sizes > 355 by request

All motors can be supplied with optional forced ventilation at additional cost.

The "R" (rib-cooled with self-ventilation) in the type designation is to be replaced with "F" (forced ventilation).

depending on requirements

... 1-: Standard Dynamic (SD) or

... 2-: High Dynamic (HD)

## Technical data/selection tables

### 4-pole, self-ventilated squirrel-cage motors, series KV.R, with reinforced ventilation

for applications with quadratically increased load torque characteristic (overload 120 %, 1 minute every 10 minutes) Without filter at the inverter output (maximum phase-to-phase pulse voltage: **2.5 kV**)

**Mains voltage: 690 V**

Type designation	Mains operation 50 Hz				Mechanical limit speed rpm	Inverter Type	Current A	Recommended cross-sections for motor connection cable mm <sup>2</sup>
	Motor torque	Motor speed	Motor torque	Motor current				
	P/kW	n/rpm	M/Nm	A (690 V)				
KV1R 132 S4	4	1440	27	4.3	3600	A		
KV1R 132 M4	5.5	1450	36	6.4	3600	A		
KV1R 160 M4	7.5	1450	49	8.4	3600	A		
KV1R 160 L4	11	1465	72	12	3000	A		
KV1R 180 M4	15	1460	98	16	3000	A		
KV1R 180 L4	18.5	1475	120	21	3000	A		
KV1R 200 L4	22	1475	143	24	3000	A		
KV1R 225 S4	30	1475	195	33	3000	A		
KV1R 225 M4	37	1475	241	40	3000	A		
KV1R 250 M4	45	1475	291	47	3000	A		
KV1R 280 S4	55	1485	355	60	3000	VSI2.0WSA1-6/0090A	90 3 x 50 + 3G10	
KV1R 280 M4	75	1485	484	79	3000	VSI2.0WSA1-6/0090A	90 3 x 50 + 3G10	
KV1R 315 S4	90	1490	579	96	3000	VSI2.0WSA1-6/0109A	109 3 x 70 + 3G10	
KV1R 315 M4	110	1485	707	117	3000	VSI2.0WSA1-6/0146A	146 3 x 95 + 3G16	
KV1R 315 MX4	132	1485	852	141	3000	VSI2.0WSA1-6/0146A	146 3 x 95 + 3G16	
KV1R 315 MY4	160	1490	1029	164	3000	VSI2.0WSA1-6/0175A	175 3 x 120 + 3G16	
KV1R 315 L4	200	1490	1286	206	3000	VSI2.0CSA1-6/0250A	250 2 x (3 x 70 + 3G10)	
KV1R 315 LX4	250	1490	1602	253	3000	VSI2.0CSA1-6/0300A	300 2 x (3 x 95 + 3G16)	
KV2R 355 MY4	280	1493	1795	296	3000	VSI2.0CSA1-6/0300A	300 2 x (3 x 95 + 3G16)	
KV2R 355 M4	300	1493	1923	312	3000	VSI2.0CSA1-6/0375A	375 2 x (3 x 150 + 3G25)	
KV2R 355 MX4	340	1495	2173	337	3000	VSI2.0CSA1-6/0375A	375 2 x (3 x 150 + 3G25)	
KV2R 355 LY4	370	1495	2372	385	3000	VSI2.0CSA1-6/0400A	400 2 x (3 x 150 + 3G25)	
KV2R 355 L4	410	1495	2628	442	3000	VSI2.0CSA1-6/0500A	500 3 x (3 x 120 + 3G16)	

A = by request

... 1-: Standard Dynamic (SD)

Motor sizes > 355 by request

All motors can be supplied with optional forced ventilation at additional cost.

The "R" (rib-cooled with self-ventilation) in the type designation is to be replaced with "F" (forced ventilation).

## Technical data/selection tables

### 4-pole, self-ventilated squirrel-cage motors, series KV.R, with reinforced ventilation

for applications with constant torque characteristic (overload 150 %, 1 minute every 10 minutes)

Without filter at the inverter output (maximum phase-to-phase pulse voltage: **2.5 kV**)

Mains voltage: **690 V**

Type designation	Inverter-fed operation											Mechanical limit speed	Maximum speed for P = constant	Inverter	Current	Recommended cross-sections for motor connection cable
	50 Hz				1:2.5		1:5		1:10							
Speed range		600 – 1500 rpm		300 – 1500 rpm		150 – 1500 rpm										
Rated motor output		Rated motor speed		Rated motor torque		Rated motor current		Motor output		Motor torque		Motor current by 690 V		Type		
P/kW	n/ rpm	M/ Nm	A (690 V)	P/ kW	M/ Nm	P/ kW	M/ Nm	P/ kW	M/ Nm	A	rpm	rpm	A	mm <sup>2</sup>		
KV1R 132 S4	4	1440	27	4.3	4	27	3.9	26	3.6	24	4.3	3600	3000	A		
KV1R 132 M4	5.5	1450	36	6.4	5.5	36	5.4	35	4.9	33	6.4	3600	3000	A		
KV1R 160 M4	7.5	1450	49	8.4	7.5	49	7.4	48	6.8	44	8.4	3600	3000	A		
KV1R 160 L4	11	1465	72	12.2	11	72	10.8	70	10	65	12.2	3000	3000	A		
KV1R 180 M4	15	1460	98	16.2	15	98	14.7	96	13.5	88	16.2	3000	3000	A		
KV1R 180 L4	18.5	1475	120	20.5	18.5	120	18.2	118	16.7	108	20.5	3000	3000	A		
KV1R 200 L4	22	1475	143	24	22	143	21.7	141	20	130	24	3000	2700	A		
KV1R 225 S4	30	1475	195	33	30	195	29.5	191	27	175	33	3000	2800	A		
KV1R 225 M4	37	1475	241	40	37	241	36.5	236	33	214	40	3000	2800	A		
KV1R 250 M4	45	1475	291	47	45	291	44	286	40.5	262	47	3000	2500	VSI2.0WSA_-6/0090A	72	3 x 50 + 3G10
KV1R 280 S4	55	1485	355	60	55	355	54	348	50	324	60	3000	2400	VSI2.0WSA_-6/0090A	72	3 x 50 + 3G10
KV1R 280 M4	75	1485	484	79	75	484	74	474	68	436	79	3000	2400	VSI2.0WSA_-6/0109A	87	3 x 70 + 3G10
KV1R 315 S4	90	1490	579	96	90	579	89	567	82	525	96	3000	2400	VSI2.0WSA_-6/0146A	117	3 x 95 + 3G16
KV1R 315 M4	110	1485	707	117	110	707	108	693	100	643	117	3000	2400	VSI2.0WSA_-6/0146A	117	3 x 95 + 3G16
KV1R 315 MX4	132	1485	852	141	132	852	130	835	121	775	142	3000	2200	VSI2.0WSA_-6/0175A	140	3 x 120 + 3G16
KV1R 315 MY4	160	1490	1029	164	160	1029	157	1008	150	962	165	3000	2700	VSI2.0CSA_-6/0250A	200	3 x 150 + 3G25
KV1R 315 L4	200	1490	1286	206	200	1286	197	1260	181	1158	207	3000	2500	VSI2.0CSA_-6/0300A	240	2 x (3 x 95 + 3G16)
KV1R 315 LX4	250	1490	1602	253	250	1602	245	1570	225	1442	253	3000	2800	VSI2.0CSA_-6/0375A	300	2 x (3 x 150 + 3G25)
KV2R 355 MY4	280	1493	1795	296	280	1795	275	1759	253	1616	297	3000	3000	VSI2.0CSA_-6/0375A	300	2 x (3 x 150 + 3G25)
KV2R 355 M4	300	1493	1923	312	300	1923	295	1884	271	1731	313	3000	3000	VSI2.0CSA_-6/0430A	344	3 x (3 x 95 + 3G16)
KV2R 355 MX4	340	1495	2173	337	340	2173	333	2130	306	1952	337	3000	3000	VSI2.0CSA_-6/0430A	344	3 x (3 x 95 + 3G16)
KV2R 355 LY4	370	1495	2372	385	370	2372	364	2325	332	2123	386	3000	3000	VSI2.0CSA_-6/0500A	400	3 x (3 x 120 + 3G16)
KV2R 355 L4	410	1495	2628	442	410	2628	403	2575	372	2378	444	3000	3000	VSI2.0CSA_-6/0595A	480	3 x (3 x 150 + 3G25)

A = by request

Motor sizes > 355 by request

All motors can be supplied with optional forced ventilation at additional cost.

The "R" (rib-cooled with self-ventilation) in the type designation is to be replaced with "F" (forced ventilation).

depending on requirements

... 1-: Standard Dynamic (SD) or

... 2-: High Dynamic (HD)

## Technical data/selection tables

### 6-pole, self-ventilated squirrel-cage motors, series KV.R, with reinforced ventilation

for applications with quadratically increased load torque characteristic (overload 120 %, 1 minute every 10 minutes) Without filter at the inverter output (maximum phase-to-phase pulse voltage: **2.5 kV**)

**Mains voltage: 690 V**

Type designation	Mains operation 50 Hz				Mechanical limit speed rpm	Inverter Type	Current A	Recommended cross-sections for motor connection cable mm <sup>2</sup>
	Motor torque	Motor speed	Motor torque	Motor current				
	P/kW	n/rpm	M/Nm	A (690 V)				
KV1R 132 M6	2.2	955	22	2.9	2400	A		
KV1R 132 MX6	3	955	30	4.1	2400	A		
KV1R 132 LX6	4	955	40	4.9	2400	A		
KV1R 160 M6	5.5	960	55	6.7	2000	A		
KV1R 160 L6	7.5	965	74	8.7	2000	A		
KV1R 180 L6	11	965	109	13	2000	A		
KV1R 200 L6	15	975	147	17	2000	A		
KV1R 200 LX6	18.5	975	182	23	2000	A		
KV1R 225 M6	22	970	217	24	2000	A		
KV1R 250 M6	30	975	294	31	2000	A		
KV1R 280 S6	37	980	361	39	2000	A		
KV1R 280 M6	45	980	439	47	2000	A		
KV1R 315 S6	55	990	533	59	2000	VSI2.0WSA1-6/0090A	90 3 x 50 + 3G10	
KV1R 315 M6	75	990	724	79	2000	VSI2.0WSA1-6/0090A	90 3 x 50 + 3G10	
KV1R 315 MX6	90	990	868	96	2000	VSI2.0WSA1-6/0109A	109 3 x 70 + 3G10	
KV1R 315 MY6	110	990	1061	115	2000	VSI2.0WSA1-6/0146A	146 3 x 95 + 3G16	
KV1R 315 L6	132	990	1280	138	2000	VSI2.0WSA1-6/0146A	146 3 x 95 + 3G16	
KV1R 315 LX6	160	990	1543	170	2000	VSI2.0WSA1-6/0175A	175 3 x 120 + 3G16	
KV2R 355 MY6	180	995	1730	202	2000	VSI2.0CSA1-6/0250A	250 2 x (3 x 70 + 3G10)	
KV2R 355 M6	200	995	1922	224	2000	VSI2.0CSA1-6/0250A	250 2 x (3 x 70 + 3G10)	
KV2R 355 MX6	250	995	2400	264	2000	VSI2.0CSA1-6/0300A	300 2 x (3 x 95 + 3G16)	
KV2R 355 LY6	300	995	2879	339	2000	VSI2.0CSA1-6/0375A	375 2 x (3 x 150 + 3G25)	

A = by request

... 1-: Standard Dynamic (SD)

Motor sizes > 355 by request

All motors can be supplied with optional forced ventilation at additional cost.

The "R" (rib-cooled with self-ventilation) in the type designation is to be replaced with "F" (forced ventilation).

## Technical data/selection tables

### 6-pole, self-ventilated squirrel-cage motors, series KV.R, with reinforced ventilation

for applications with constant torque characteristic (overload 150 %, 1 minute every 10 minutes)

Without filter at the inverter output (maximum phase-to-phase pulse voltage: **2.5 kV**)

**Mains voltage: 690 V**

Type designation	Inverter-fed operation											Mechanical limit speed	Maximum speed for P = constant	Inverter	Current	Recommended cross-sections for motor connection cable
	Control range		50 Hz		1:2.5		1:5		1:10							
Speed range		400 – 1000 rpm		200 – 1000 rpm		100 – 1000 rpm										
Type	Rated motor output	Rated motor speed	Rated motor torque	Rated motor current	Motor output	Motor torque	Motor output	Motor torque	Motor output	Motor torque	Motor current by 690 V	rpm	rpm	A	mm <sup>2</sup>	
	P/kW	n/ rpm	M/Nm	A (690 V)	P/ kW	M/ Nm	P/ kW	M/ Nm	P/ kW	M/ Nm	A	rpm	rpm	A	mm <sup>2</sup>	
KV1R 132 M6	2.2	955	22	2.9	2.2	22	2.2	22	2	20	2.9	2400	2000	A		
KV1R 132 MX6	3	955	30	4.1	3	30	2.9	29	2.7	27	4.1	2400	2000	A		
KV1R 132 MX6	4	955	40	4.9	4	40	3.9	39	3.6	36	4.9	2400	1700	A		
KV1R 160 M6	5.5	960	55	6.7	5.5	55	5.4	54	4.9	49	6.7	2000	1700	A		
KV1R 160 L6	7.5	965	74	8.7	7.5	74	7.3	73	6.7	67	8.7	2000	1700	A		
KV1R 180 L6	11	965	109	13	11	109	10.8	107	9.9	98	13	2000	2000	A		
KV1R 200 L6	15	975	147	17	15	147	14.7	144	13.5	132	17	2000	1800	A		
KV1R 200 LX6	18.5	975	182	23	18.5	182	18	178	16.7	164	23.1	2000	1800	A		
KV1R 225 M6	22	970	217	23.5	22	217	22	213	19.8	195	23.5	2000	1800	A		
KV1R 250 M6	30	975	294	31	30	294	29	288	27	264	31	2000	1700	A		
KV1R 280 S6	37	980	361	39	37	361	36	353	33	325	39	2000	1500	VSI2.0WSA_-6/0090A	72	3 x 50 + 3G10
KV1R 280 M6	45	980	439	47	45	439	44	430	41	395	47	2000	1800	VSI2.0WSA_-6/0090A	72	3 x 50 + 3G10
KV1R 315 S6	55	990	533	59	55	533	54	523	50	480	59	2000	1800	VSI2.0WSA_-6/0090A	72	3 x 50 + 3G10
KV1R 315 M6	75	990	724	79	75	724	74	709	68	651	79	2000	1800	VSI2.0WSA_-6/0109A	87	3 x 70 + 3G10
KV1R 315 MX6	90	990	868	96	90	868	88	851	81	781	96	2000	1800	VSI2.0WSA_-6/0146A	117	3 x 95 + 3G16
KV1R 315 MY6	110	990	1061.1	115	110	1061	108	1040	99	955	115	2000	1800	VSI2.0WSA_-6/0146A	117	3 x 95 + 3G16
KV1R 315 L6	132	990	1279.8	138	133	1280	130	1254	119	1152	139	2000	1800	VSI2.0WSA_-6/0175A	140	3 x 120 + 3G16
KV1R 315 LX6	160	990	1543.4	170	160	1543	157	1513	144	1389	170	2000	2000	VSI2.0CSA_-6/0250A	200	3 x 150 + 3G25
KV2R 355 MY6	180	995	1730.0	202	180	1730	177	1695	162	1557	202	2000	1600	VSI2.0CSA_-6/0250A	200	2 x (3 x 70 + 3G10)
KV2R 355 M6	200	995	1921.5	224	200	1922	196	1883	180	1729	224	2000	1700	VSI2.0CSA_-6/0300A	240	2 x (3 x 95 + 3G16)
KV2R 355 MX6	250	995	2399.5	264	250	2400	245	2352	225	2160	264	2000	1800	VSI2.0CSA_-6/0375A	300	2 x (3 x 150 + 3G25)
KV2R 355 LY6	300	995	2879.4	339	300	2879	294	2822	270	2591	339	2000	1900	VSI2.0CSA_-6/0430A	344	3 x (3 x 95 + 3G16)

A = by request

Motor sizes > 355 by request

All motors can be supplied with optional forced ventilation at additional cost.

The "R" (rib-cooled with self-ventilation) in the type designation is to be replaced with "F" (forced ventilation).

depending on requirements

... 1-: Standard Dynamic (SD) or

... 2-: High Dynamic (HD)







## **ELECTRIC DRIVES**

FOR EVERY DEMAND

### **VEM GmbH**

Pirnaer Landstraße 176  
01257 Dresden  
Germany

### **VEM Sales**

Low voltage department  
Fon +49 3943 68-3127  
Fax +49 3943 68-2440  
E-Mail: [low-voltage@vem-group.com](mailto:low-voltage@vem-group.com)

High voltage department  
Fon +49 351 208-3237  
Fax +49 351 208-1108  
E-Mail: [high-voltage@vem-group.com](mailto:high-voltage@vem-group.com)

Drive systems department  
Fon +49 351 208-1154  
Fax +49 351 208-1185  
E-Mail: [drive-systems@vem-group.com](mailto:drive-systems@vem-group.com)

### **VEM Service**

Fon +49 351 208-3237  
Fax +49 351 208-1108  
E-Mail: [service@vem-group.com](mailto:service@vem-group.com)

**[www.vem-group.com](http://www.vem-group.com)**