

Installation and Operating Instructions for ROBA-stop[®]-Positioning Brake Type 80_.41_._ Sizes 3 – 11

(B.1110.1.GB)

Please read and observe this Operating Instruction carefully!
A possible malfunction or failure of the brake and any damage may be caused by not observing it.

Table of contents:

- Page 1:** - Table of contents
- Manufacturer's declaration
- Page 2:** - Safety regulations
- Page 3:** - Safety regulations
- Page 4:** - Brake view
- Parts list
- Scope of delivery
- Function description
- Page 5:** - Assembly conditions
- Assembly
- Air gap adjustment
- Page 6:** - Table 2 Air gap adjustment
- Braking torque adjustment
- Brake inspection
- Exchange of the wearing parts
- Page 7:** - Assembly of the hand release
- Adjustment of the hand release
- Parts list hand release
- Page 8:** - Electric connection
- Assembly terminal box
- Page 9:** - Maintenance
- Disposal
- Breakdowns

Manufacturer's declaration

The product is to be seen as an option or component for installation into machines or equipment according to the machinery directive 98/37 EC. The machinery (product) must not be put into service until the machinery or equipment into which it is to be incorporated has been declared in conformity with the provisions of the applicable EC-directives.

The product corresponds to the low voltage directives 73/23/EEC.

The observance of the relevant EMC-directive 89/336/EEC is to be guaranteed.

Installation and Operating Instructions for ROBA-stop[®]-Positioning Brake Type 80_41_._ Sizes 3 – 11

(B.1110.1.GB)

Safety regulations

With these safety regulations no claim on completeness is raised!



Attention!

Hazardous conditions when contacting hot connections and components.

Only qualified and well-trained specialists should work on the units to avoid any personal injury or damage to machinery.

Danger!

If the electromagnetic brake is used in an improper way.
If the electromagnetic brake has been modified or reconverted.
If the relevant standards of the safety or installation conditions are not observed.



Attention!

The installation and operating instructions must be read carefully and all safety regulations observed before installation and initial operation as danger to personnel and damage to machinery may be caused.

The electromagnetic brakes are developed and manufactured in conformance with the temporarily known rules of the technology and they are basically considered as fail-safe at the time of the delivery.

Attention:

Based on the guideline 94/9/EC (ATEX-guideline) this product is not suitable for the application in potential explosive areas without evaluation of the conformity.

Observe!

- Only qualified and well trained specialists who are familiar with the transport, installation, initial start-up, maintenance and operation of the units as well as with the relevant standards may carry out the corresponding works.
- Technical data and indications (Type tag and documentation) are to be kept absolutely.
- Correct supply connection according to Type tag.
- Supply connections must not be released and assembly, maintenance or repair must not be made when the unit is energised.
- Electrical leads must not be under tension when connected.
- Check current carrying components regarding damage before installation. Current carrying components must not be in contact with water.
- The braking torque does not exist any more, if the friction lining and friction surface come into contact with oil or grease.

Intended use

mayr[®]-brakes are determined for the use in machines and equipment and may only be used for the ordered and confirmed purpose.

The use beyond of the corresponding technical indications is considered as incorrect.

Notes to the electromagnetic compatibility (EMC)



There are no emissions from the listed single components within the meaning of the EMC-directive 89/336/EEC, however, increased interference levels can occur when working components are operated outside their specification limits as for example, energising the brake in the line side with rectifiers, phase demodulators or ROBA[®]-switch in the line side.

Therefore, the installation and operating instructions must be read carefully the EMC-directives are to be observed.

Conditions of the unit



The catalogue values are reference values, which can deviate in some cases. When selecting the brake, site of installation, braking fluctuations, permissible friction work, behaviour during run-in, wear and ambient conditions are to be carefully checked and agreed with the unit manufacturer.

Observe!

- The mounting and connecting dimensions at the site of installation must match to the size of the brake.
- The brakes are designed for a relative switch on period of 100 %.
- The brakes are designed for a dry running only. Should oil, grease, water or similar materials come in contact with the friction surfaces the braking torque could be reduced.
- The braking torque depends on the corresponding running-in condition of the brake
- The metallic surface of the brake is protected against corrosion arranged by the factory.

Protection class I

The protection is not only based on the basis isolation, but that all conductive components must be connected with the protective conductor (PE) of the fixed installation. In case the basis isolation fails, no contact voltage can remain existing. (VDE 0580).

Protection (electrical) IP 54:

Dust-tight and protection against contact as well protection against splashing water from all directions.

Ambient temperature –20 °C up to +40 °C

Attention!

The torque could be severely reduced in case of temperatures over or under the freezing point due to dewing. The user must provide corresponding counter measures.

Thermal class F (+155 °C)

The magnetic coil as well as the casting compound is designed for a max. operating temperature of +155 °C.

Installation and Operating Instructions for ROBA-stop[®]-Positioning Brake Type 80_41_._ Sizes 3 – 11

(B.1110.1.GB)

Safety Regulations

With these safety regulations no claim on completeness is raised!

Necessary protective measures to be undertaken by the user:

Cover all moving parts to prevent personnel injury as squeezing and seizing and centrifuging out.

Cover dangerously hot magnetic parts to prevent contact.

Attach a conductive connection between magnetic part and electrical conductor (PE) of the fixed installation (protection class I) to prevent electrical shock and inspection conforming to standards of the unified protective connection to all contactable metallic components. Protection against high inductive cut-off peaks according to VDE 0580/2000-07, par. 4.6 by fitting varistors, spark quenching units or similar, in order to prevent damage of coil insulations or the burn-off of the switching contact (this protection is included in *mayr*[®]-rectifiers).

Provide additional necessary safety measures against corrosion of the brake, if they are used in extreme ambient conditions or in the open with direct atmospheric influences.

Measures against freezing from armature disc and rotor with high humidity and deep temperatures.

Following directives, standards and guidelines have been used:

98/37/EC	Machinery directive
73/23/EEC	Low-voltage directive
89/336/EEC	EMC-directive
DIN VDE 0580	Electromagnetic units and components, general regulations

Following standards are to be observed:

EN292-1 and 2	Security of machines
DIN EN61000-6-4	Interference emission
DIN EN61000-6-2	Interference resistance
EN60204	Electrical equipment of machines

Liability

- The information, notes and technical data indicated in the documentation were at the time of printing on the latest state.

Claims on brakes already supplied cannot be made valid from it.

- Liability for damages and breakdowns is not taken over, with
 - ignoring the installation and operating instructions,
 - improper use of the brakes,
 - arbitrary modification of the brakes,
 - inappropriate working at the brakes,
 - handling or operating errors.

Guarantee

- The warranty conditions correspond to the sales and supply conditions of Chr. Mayr GmbH + Co. KG.
- Defects are to be advised immediately after detection to *mayr*[®].

Test mark

CE corresponding to the low voltage directive 73/23/EEC.

Marking

mayr[®]-components are clearly identified by means of the content of the Type tags.

Manufacturer
<i>mayr</i>[®]
Designation/Type
Article No.
Series number

Installation and Operating Instructions for ROBA-stop[®]-Positioning Brake Type 80_41_.. Sizes 3 – 11

(B.1110.1.GB)

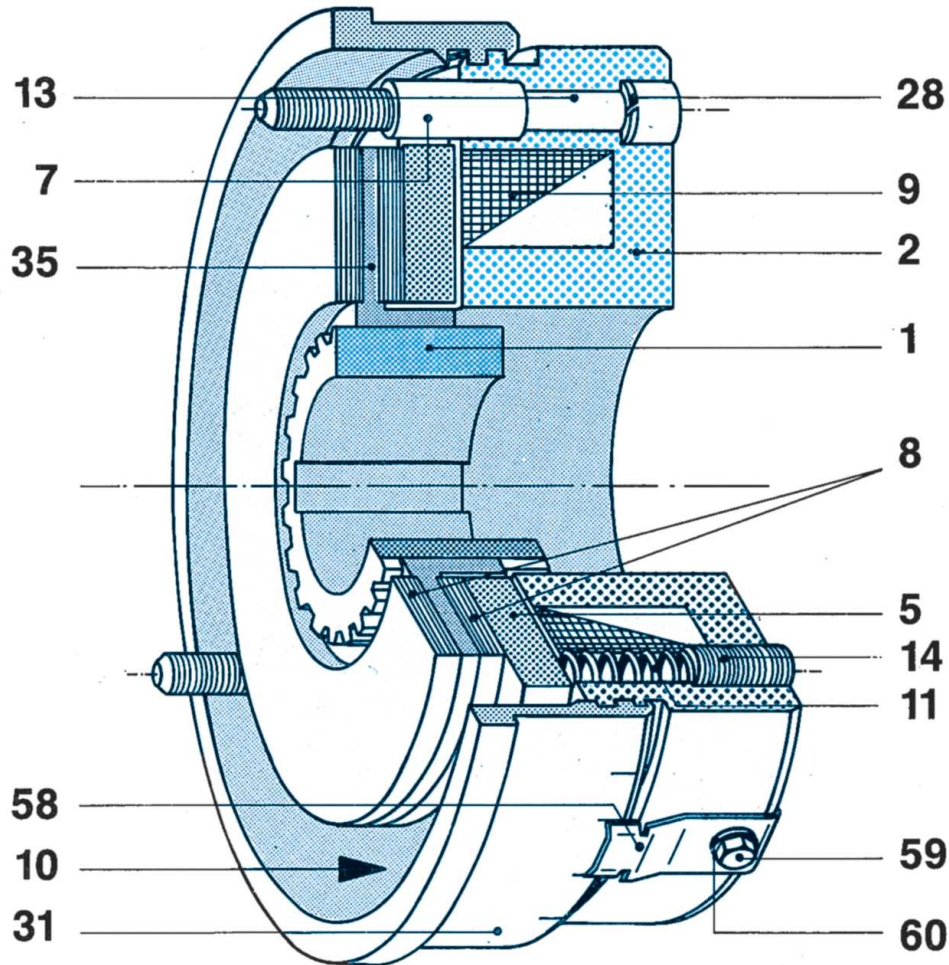

Fig. 1

Parts List

1 Gear hub	13 Fixing screw
2 Coil carrier complete with coil (9) and guide bushes (7)	14 Setscrew
5 Armature disc	28 Spring washer
7 Guide bush	31 Threaded distance ring
8 Friction lining	35 Rotor with friction linings (8)
9 Coil	58 Lock washer
10 Shoulder screw	59 Locking screw
11 Helical spring	60 Spring washer

Delivery range / Delivery condition:

The scope of supply or the delivery condition must immediately be checked after receipt of the shipment. **mayr[®]** does not overtake any guarantee for faults complained subsequently.

Claim:

Transportation damages immediately with the forwarder. Recognizable faults / incompleteness of the shipment immediately in the manufacturing company.

Functional description

The braking torque is generated by the applied force of several helical springs (11) by means of a frictional locking between both friction linings of the rotor (35), the armature disc (5) and machine wall.

The brake is released electromechanically or mechanically by means of a hand release (see page 6).

Installation and Operating Instructions for ROBA-stop®-Positioning Brake Type 80_41_._ Sizes 3 – 11

(B.1110.1.GB)

Assembly conditions

Before attachment of the brake, the following points must be observed:

- The eccentricity of the shaft end against the fixing hole P.C.D. must not exceed 0,2 mm (with sizes 3 – 6), or with larger brakes it must not exceed 0,4 mm.
- The positioning tolerance of the thread for the cap screws (13) must not exceed 0,2 mm.
- The deviation in the true running of the screw-on surface to the shaft must not exceed the permissible true running tolerance according to DIN 42955 R.
Reference diameter is the pitch circle diameter for brake attachment.
Larger deviations can cause a reduction in torque, a continuous wear of the rotor and overheating.
- The hub and shaft fits are to be selected to avoid any distortion of the hub splines (observe the max. joining temperature of 200°C). It can clamp the rotor on the hub impairing the brake function, (recommended hub-shaft fit H7/k6).
- The hub (1) is to be brought in such position that the toothing of the rotor (35) supports across the entire surface.
- Rotors and braking surfaces must be free of oil and grease.
- There has to be a suitable counter friction surface for the rotor (35) made from steel or cast iron. Sharp-edged interruptions of the friction surface must be avoided.

Assembly

- Mount the gear hub (1) onto the shaft and lock it axially. Avoid damaging the toothing.
The gear hub (1) is to be mounted in such a way that the toothing of the rotor (35) remains completely engaged, even when the friction linings (8) are worn down.
- Push the rotor (35) manually onto the gear hub (1).
The rotor collar points to the brake.
Ensure that the splines slide easily.
No damage.
- Attach the brake using the included fixing screws (13) and lock it by means of the spring washers (28).
Observe the screw tightening torques according to Table 1.
Check the air gap (a_1, a_2). Fig. 2 nominal air gap (a_1, a_2) according to Table 2 must be available. The shoulder screws (10) Figs. 1 and 4 prevent the individual parts from coming apart.
They do not impair the function of the brake and should not be removed during assembly.

Table1

ROBA-stop® Size	3	4	5	6	7	8	9	10	11
Fixing screws	3x M4	3x M4	3x M5	3x M6	3x M6	3x M8	6x M8	6x M8	6x M12
Tightening torques [Nm]	3	3	6	8	8	10	10	10	40

Air gap adjustment

The working air gap between armature disc (5) and coil carrier (2) is adjusted to the nominal dimension (a_1, a_2) in the factory, Fig. 2 and Table 2

The size of the nominal air gap depends on the structural form of the armature disc (5). The third figure of the Type number informs on the fitted armature disc.

As the rotor friction material (35) wears down, the air gap (a_1, a_2) increases. By turning the graduated distance ring (31) the nominal air gap can be restored. The adjustment has to be carried out at the latest, when the maximum permissible working air gap according to Table 2 is achieved.

Re-adjustment

1. Remove a plug from the threaded distance ring (31). Measure the air gap in a de-energised condition with a feeler gauge before an adjustment. The difference between the measured air gap and nominal air gap (a_1, a_2) according to Table 2 must be re-adjusted.
2. Loosen the fixing screws (13).
3. Release the locking screw (59) and lock washer (58).
4. Turn the threaded distance ring (31) counter-clockwise (when looking at brake back side). Turning the distance ring (31) by one graduation of the stamped scale corresponds to an air gap adjustment for the sizes 3 to 6 of 0,05 mm, for the sizes 7 to 11 of 0,1 mm.
5. Tighten the fixing screws (13), observe the tightening torques according to Table 1.
6. Tighten the clamping screw (59).
7. Check the air gap; nominal air gap (a_1, a_2), according to Table 2 must be available.

This adjustment can be repeated so often, until the graduated distance ring (31) contacts the rod-stop of the coil carrier (2), Fig. 2. This contact avoids an unacceptable wear of the rotor (35). If a re-adjustment is not possible any more, the rotor (35) must be exchanged. You can find data on the rotor thickness in a new condition and thickness after a max. wear in Table 2.

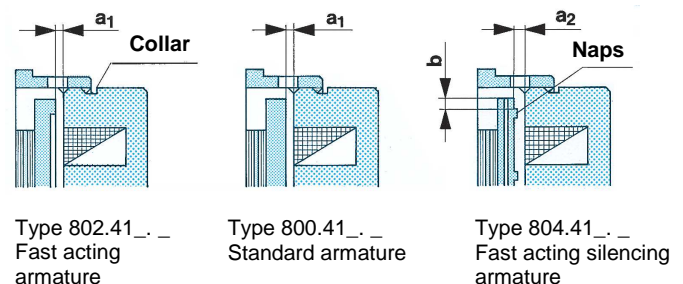

Fig. 2

Installation and Operating Instructions for ROBA-stop[®]-Positioning Brake Type 80_.41_. Sizes 3 – 11

(B.1110.1.GB)

Table 2

ROBA-stop [®]	Size	3	4	5	6	7	8	9	10	11
Nominal air gap Type 80_ "a ₁ "	[mm]	0,20	0,20	0,25	0,25	0,35	0,35	0,40	0,40	0,50
Nominal air gap Type 804 "a ₂ "	[mm]	0,35	0,35	0,40	0,45	0,60	0,60	0,65	0,70	0,80
Dimension b (Fig. 2)	[mm]	no naps		4,25	4,50	4,50	6,25	no naps		
Max. air gap * (with nominal torque)	[mm] Type 800	0,40	0,45	0,75	0,85	0,90	1,0	1,0	1,1	1,6
	Type 802	0,35	0,40	0,70	0,75	0,80	0,85	0,85	0,90	1,4
Rotor thickness in a new condition	[mm]	5	6	7	8,5	11	12,5	15	17	24
Rotor thickness after complete wear	[mm]	3,5	4,35	5,2	6,55	8,9	10,2	12	13,4	20,1

* The max. working air gap can be reduced with increasing working temperature.

Braking torque adjustment

ROBA-stop[®]-brakes are adjusted to the braking torque requested in the order in the factory. The braking torque is reduced by turning the set screws (14) counter-clockwise and increased by turning them clockwise. All set screws (14) must be uniformly adjusted, when the braking torque is adjusted.



Attention!

Do not interchange set screws (14) with fixing screws (13) by mistake!

In case the braking torque shall be essentially reduced, the helical springs (11) must be removed. Always two springs lying opposite should be taken out so that the armature (6) is uniformly loaded.

Friction lining side



Type 802.41_. _
Fast acting armature

Brake inspection

The full adjusted braking torque is only achieved after the run-in process has been carried out.

The braking torque (switching torque) is the slipping torque acting on the shafting at a running speed of 1 m/s referred to the mean friction radius (acc. to DIN VDE 0580/10.94).

Table 3

ROBA-stop [®] Size	3	4	5	6	7	8	9	10	11
Set screws	6x M5	6x M6	6x M10	6x M10	12x M10	12x M14	12x M8	12x M10	16x M12
Number of brake springs	6	6	6	6	12	12	12	12	16

Type 800.41_. _
Standard armature

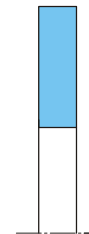

Exchange of the wearing parts

The rotor (35), armature disc (5) and gear hub (1) are wearing parts. Unscrew the brake (remove the fixing screws (13)), exchange the rotor (35). If there is extreme clearance in the toothing between rotor (35) and gear hub (1), pull off the gear hub (1) from the shaft and replace it. Furthermore check the armature disc (5) as to plane parallelity and check the wear and exchange it, if necessary.

Restore the nominal air gap via the distance ring (31). The shoulder screws (10) as well as the hand release (if available) must be removed for exchanging the armature disc (5). Pay attention that the helical springs (11) do not fall out. The armature disc (5) can be different depending on the brake Type.

Therefore, observe the mounting position, Fig. 3.

Magnetic elem. side

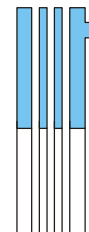

Type 804.41_. _
Fast acting
silencing armature

Fig. 3

Installation and Operating Instructions for ROBA-stop[®]-Positioning Brake Type 80_41_._ Sizes 3 – 11

(B.1110.1.GB)

Assembly of the Hand release¹⁾

The hand release can be mounted to each Type of the positioning brake, with the exception of the Type 804.41_._ (Brake with fast acting silencing armature disc).

The brake must be dismantled and de-energised for the assembly.

- Push the return spring (19) onto the restoring bolt (17).
- Take out the plastic plugs from the bores on the back side of the coil carrier (2).
- Push the restoring bolt (17) through the recesses in the armature disc (5) and through the bores in the coil carrier (2).
- Bolt the hand release bracket (22) with the locking nuts (21) onto the restoring bolt (17).

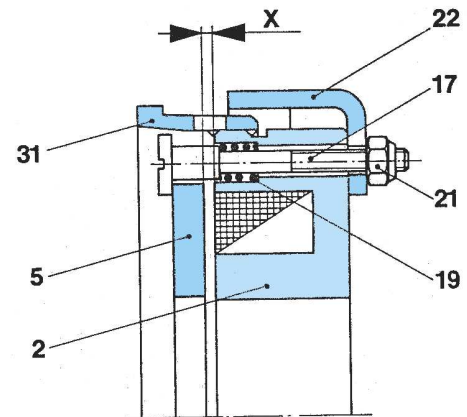

Fig. 5

Fitting the hand release

The restoring bolts (17) limit the stroke of the armature disc (5) in brake direction, Figs. 4 and 5.



Attention:

The restoring bolts (17) may only be tightened by the locking nuts (21) so that the adjusting dimension "X" according to Table 4 and Fig. 5 remains existing at least between armature disc (5) and coil carrier (2).

Table 4

ROBA-stop [®]	Size	3	4	5	6	7	8	9
Adjusting dim. "X"	[mm]	1,0	1,1	1,2	1,6	1,4	1,5	1,5

1) Please contact the factory regarding the hand release sizes 10 and 11.

Parts List hand release

- 10 Shoulder screw
- 16 Threaded bolt
- 17 Restoring bolt
- 18 Ball button
- 19 Return spring
- 21 Lock nut
- 22 Hand release bracket

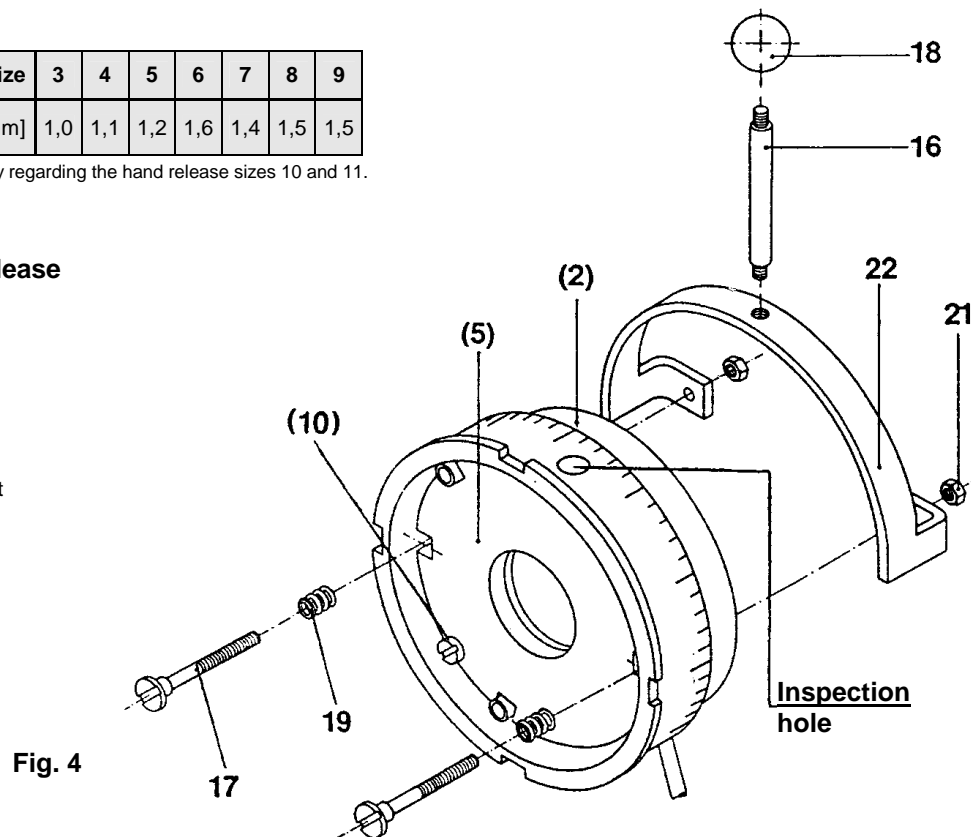

Fig. 4

Installation and Operating Instructions for ROBA-stop®-Positioning Brake Type 80_41_._ Sizes 3 – 11

(B.1110.1.GB)

Electric connection



Warning!

Electrical connection only in a voltage free condition.
The coil voltage is indicated on the Type tag, additionally it is stamped on the brake.

The brakes are designed according to Euro-voltage DIN IEC 38.

DC current is necessary for the operation.

DC or AC current switchings are possible.
DC current switching, however, gains a faster engaging time (engagement of the brake).

In case a faster disconnection time of the brake is desired, a special ROBA®-switch fast acting rectifier is necessary.
In this case please contact our company.

Attention!

Cut-off peaks may arise during switching-off of electromagnetic units. These can cause damage to the units and are, therefore, to be damped.

The connection times indicated in the catalogue can be deteriorated by this damping.

A protection of the voltage supply according to the current values is to be provided.

The brakes are designed for a relative duty cycle of 100 %.

Assembly terminal box

Panel (44) mounted by choice with:

1. Terminal 2-poles
2. Terminal 4-poles
3. Terminal 6-poles
4. Half-wave rectifier
5. Bridge rectifier

Parts list terminal box

- 37 Holding bracket
- 38 Cap screw M3 x 12
- 39 Terminal box – lower part
- 40 O-ring
- 41 Sealing plate
- 42 Hexagon nut M3
- 43 Cable gland
- 44 Panel
- 45 Countersunk screw M4 x 8
- 46 Terminal
- 47 Terminal marking
- 48 Cap screw M2,5 x 12
- 49 Cap screw M4 x 8
- 50 Terminal box cover
- 51 Sealing ring
- 52 Cap screw M4 x 30
- 53 Sealing washer

The components 37 to 43 of the parts list are pre-assembled.

1. a) Screw rectifier into the terminal box - lower part (39) or
1. b) screw panel (44) into the terminal box – lower part (39) with the countersunk screws (45). Mount the terminals with 2-, 4- or 6-poles (46) with caps screws onto the panel (44). Glue the terminal marking (47) onto the panel (44). (Observe the position of the terminal marking acc. to Fig. 5).
2. Cut the cable of the brake coil to the suitable length and strip it. Lead the cable into the terminal box through the components 39, 40 and 41.
3. Screw the holding bracket (37) with cap screws (49) to the brake back side.
4. Pull the brake coil, tighten the hexagon nuts (42).
5. Connect the brake acc. to the installation and operating instructions No. B.1110.4.GB for ROBA-stop®-brakes / electric connection“.
6. Close the terminal box. Observe the sealing (51) and sealing washers (53).

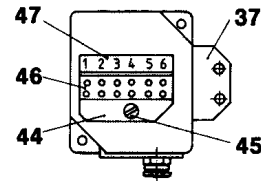

Fig. 6

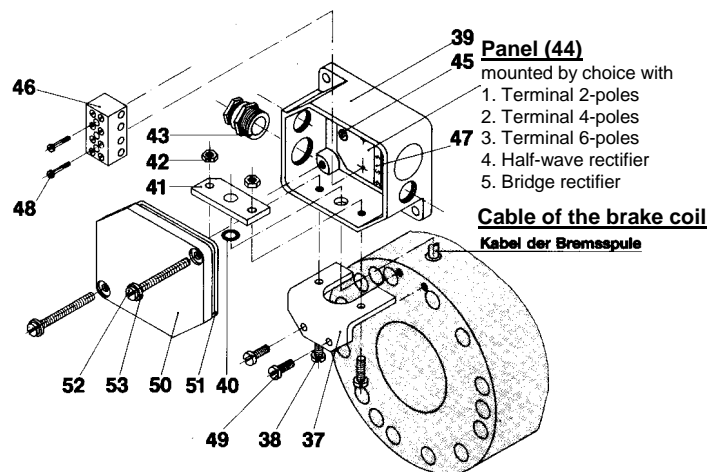

Fig. 7

Maintenance

ROBA-stop®-brakes are virtually maintenance free.

The friction linings are robust and wear resistant ensuring a very

Attachment

18/11/2004 K/KR

Chr. Mayr GmbH + Co. KG
Eichenstraße 1
87665 Mauerstetten
Germany

Tel.: 08341 / 804-241
Fax: 08341 / 804-422
http://www.mayr.de
eMail: info@mayr.de

mayr[®]
Antriebstechnik

Installation and Operating Instructions for ROBA-stop[®]-Positioning Brake Type 80_.41_._ Sizes 3 – 11

(B.1110.1.GB)

long brake service life.

However, the gear hub (1), armature disc (5) as well as the rotor with friction linings (35) are subject to wear and must be checked at regular intervals and exchanged, if necessary. See for this the chapter "Exchange of the wearing parts".

Disposal

Electronic components

(rectifier / ROBA[®]-switch / micro switch):

The not disassembled products can be supplied to the material utilization according to EAK 150106 (mixed material) or via the household waste (code No. 200301) to the disposal.

The components of our Electromagnetic Brakes must separately be supplied to the utilisation due to the different material components. Additionally the legal instructions are to be observed. Code numbers can change with the kind of the separation (metal, plastic and cable).

Brake body made of steel with coil/cable and all other steel components:

Scrap (Code No. 160117)

Distance ring made of aluminium:

Non-ferrous metal (Code No. 160118)

Brake rotor (steel or aluminium with friction lining):

Brake linings (Code No. 160112)

Seals, O-rings, V-Seal, Elastomere, Terminal boxes (PVC):

Plastic (Code No. 160119)

Breakdowns:

Failures	Possible reasons	Solution
Brake does not release	<input type="checkbox"/> False voltage measured at the rectifier <input type="checkbox"/> Rectifier failed <input type="checkbox"/> Air gap too big (rotor worn down) <input type="checkbox"/> Air gap too big (metallic particles between armature disc and coil carrier) <input type="checkbox"/> Coil interrupted <input type="checkbox"/> Brake becomes too warm	<input type="checkbox"/> Apply correct voltage <input type="checkbox"/> Exchange rectifier <input type="checkbox"/> Replace rotor <input type="checkbox"/> Clean the brake <input type="checkbox"/> Exchange the brake <input type="checkbox"/> Use fast acting rectifier
Motor does not brake	<input type="checkbox"/> Hand release is adjusted falsely <input type="checkbox"/> Hand release play; (possible with decreased torque or operation with fast acting rectifier)	<input type="checkbox"/> Adjust the distance correctly <input type="checkbox"/> Replace rotor
Brake engages with delay	<input type="checkbox"/> Brake is switched to AC side	<input type="checkbox"/> Switch to DC side